

FlowMaster Tomographic PIV

Volumetric Flow Field Imaging
- the ultimate solution for quantitative flow visualization -



LAVISION

FOCUS ON IMAGING

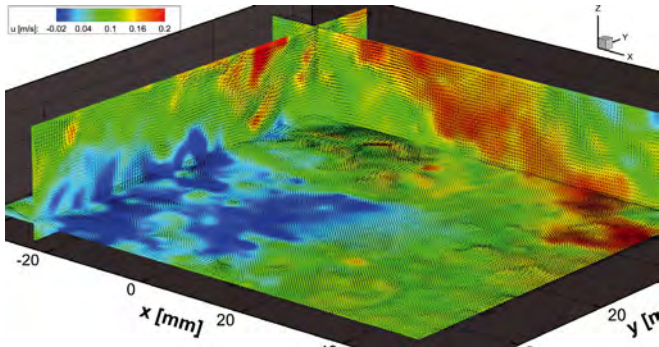

3 Velocity Components in 3 Dimensions: 3D3C PIV,
courtesy D. Schanz, DLR

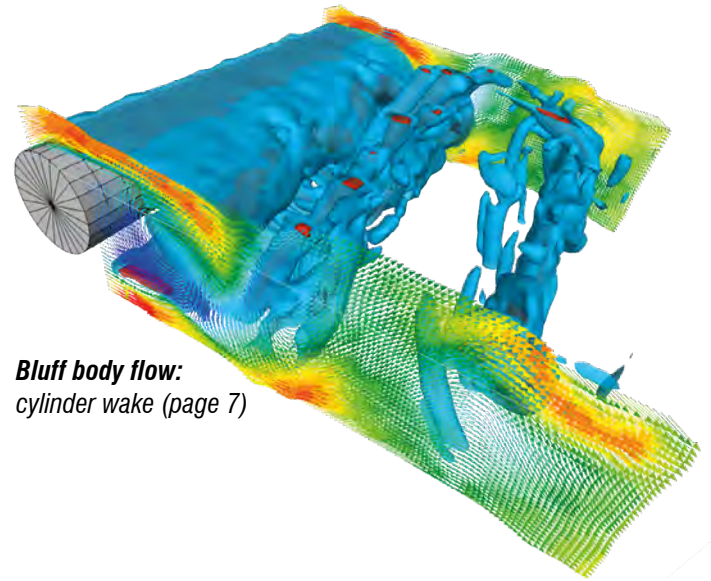

Bluff body flow:
cylinder wake (page 7)

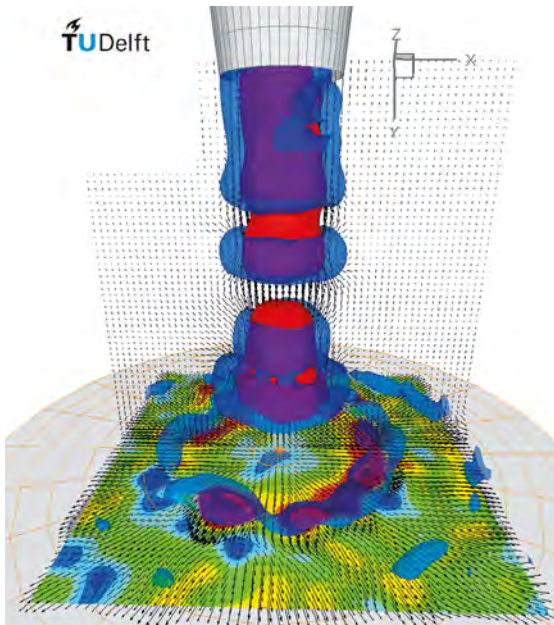

Time-resolved Tomo-PIV: impinging jet [2]

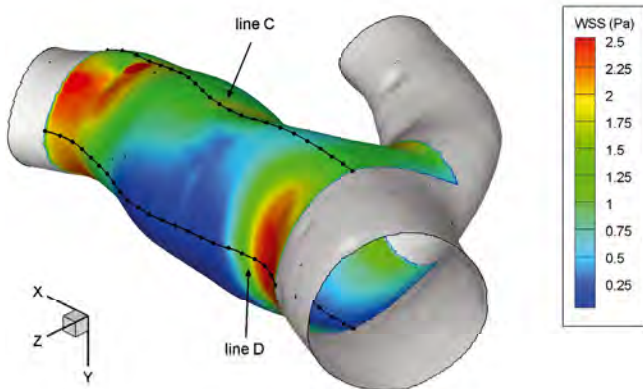

Biofluids: carotid artery shear stress (page 19)

Flexible and robust volumetric flow measurement solutions

Turbulent flows are 3-dimensional (3D) in nature. While 2D (laser) imaging cannot resolve turbulent flow structures in all three dimensions, tomographic reconstruction techniques using multiple views are capable to capture instantaneously complex flow structures in all three dimensions. From time-correlated volume images, instantaneous 3D flow fields are derived applying a 3D correlation technique on volume elements (voxels)[1, TU-Delft].

LaVision's powerful **FlowMaster** laser imaging systems based on Tomographic Particle Image Velocimetry (Tomo-PIV) and Tomographic Particle Tracking Velocimetry (Tomo-PTV) capture instantaneous volumetric flow fields in highly turbulent flows, flames as well as sprays with outstanding spatial resolution.



3D flame imaging (page 14)

References:

- [1] Scarano, Meas. Sci. Technol. 24, 2013
- [2] Violato et al., Proc. ASME Engineering Conf. Hamamatsu, Japan, 2011

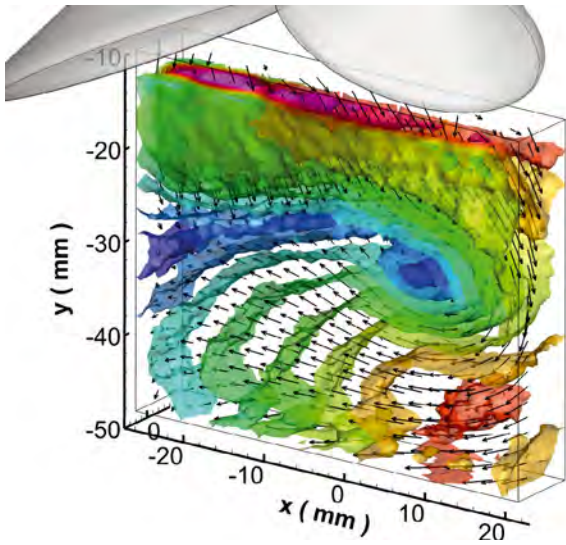

In-cylinder volumetric (3D3C) flow field (page 17)

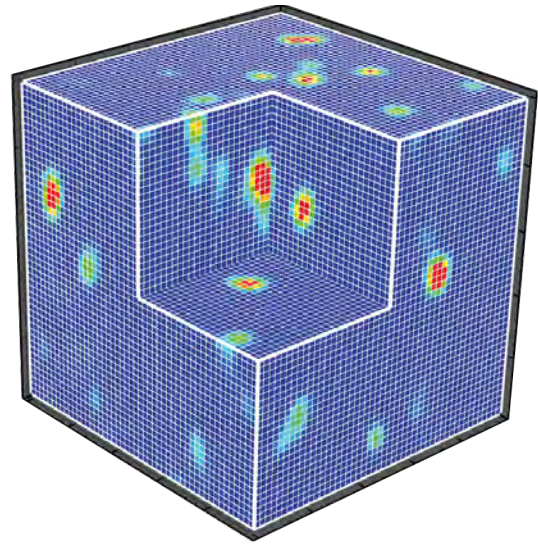

3D reconstruction: voxels in 3D space (page 4)

Due to the unique modular imaging concept our **FlowMaster** Stereo-PIV systems can be upgraded straight forward for 3D tomographic imaging applications. Furthermore, our high-speed **FlowMaster** Tomo-PIV systems allow time-resolved flow field imaging in 3D-space—revealing **the complete 4D-information of dynamically changing flows!**

The unsurpassed performance of LaVision's **FlowMaster** Tomo-PIV systems are proven in challenging applications such as turbulent flow studies, animal locomotion and 3D-imaging of flames and sprays. This outstanding performance is achieved by using latest technologies like MART reconstruction, direct correlation and Volume Self-Calibration.

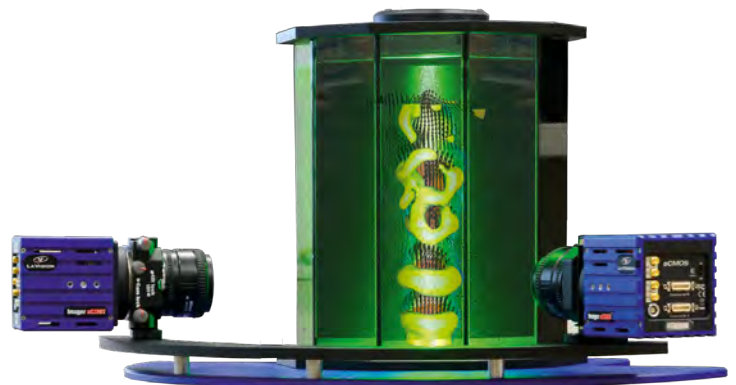

3D flow field of a liquid jet (page 7)

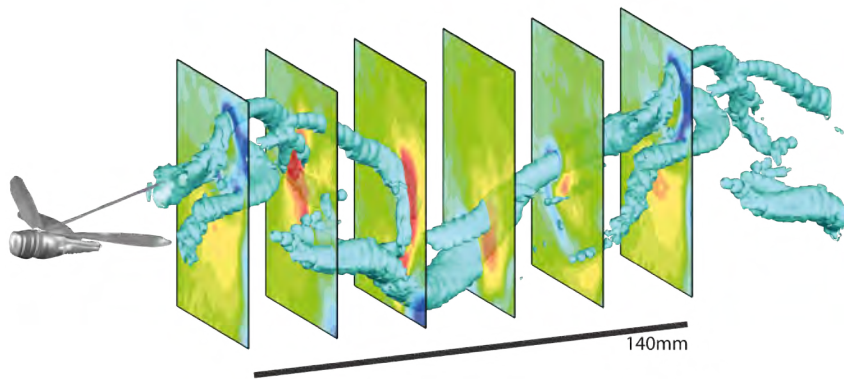

Insect flight (page 10)

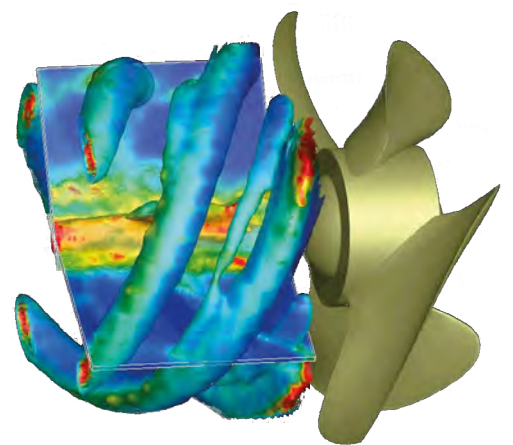

Propeller induced 3D flow field (page 16)

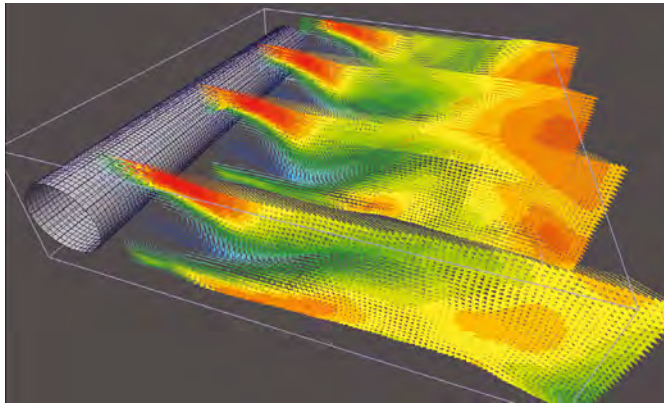

Tomographic reconstruction and 3D cross-correlation of voxel intensities

Tracer particles within the measurement volume are illuminated by a high power pulsed light source and the scattered light pattern is recorded simultaneously from typically 4 viewing directions using high resolution cameras. ❶

The 3D particle distribution is reconstructed by a **tomographic reconstruction** algorithm (Multiplicative Algebraic Reconstruction Technique, MART) as a 3D light intensity distribution for each voxel. ❷

The particle displacement within a chosen interrogation volume is then obtained by **3D cross-correlation** of the reconstructed particle distribution at two exposures separated by a short time step Δt using advanced iterative multi-grid algorithms with deformed interrogation volumes. ❸

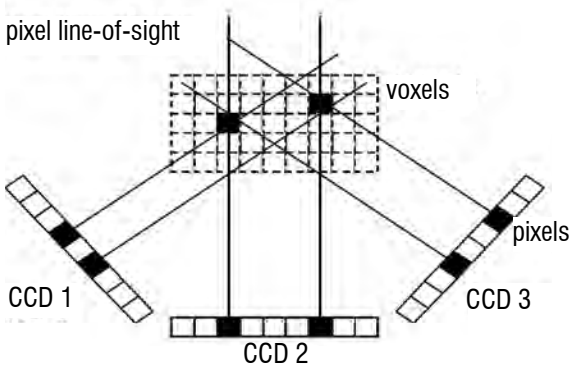

MART reconstruction algorithm

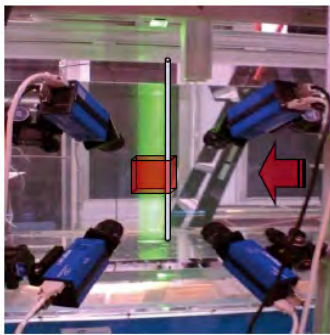

acquire projections

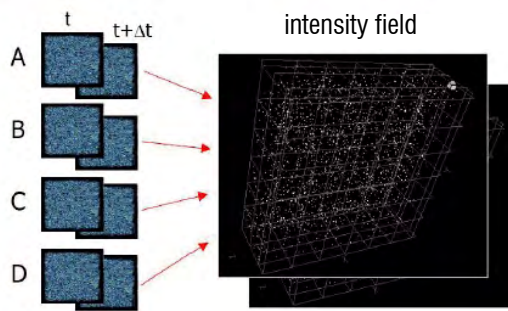
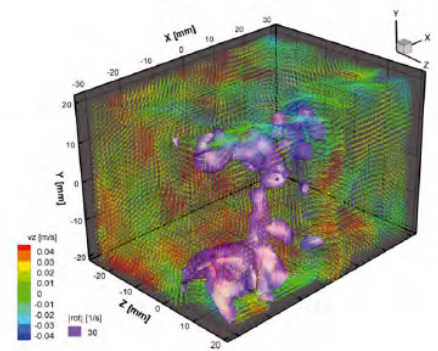
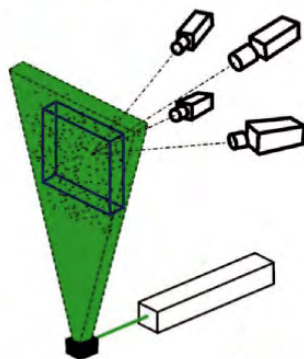

image volumes



displacement of velocity fields



❶



reconstruction

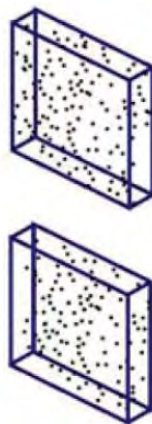

❷

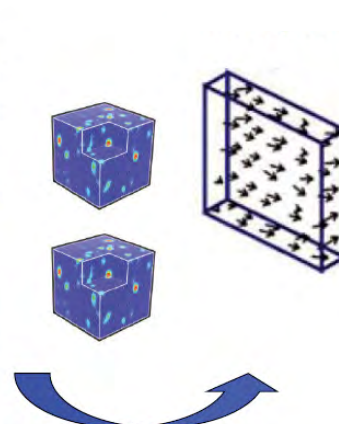

cross-correlation

❸



High precision camera calibration for 3D reconstruction

A precise volumetric calibration based on a calibration target is required for all tomographic imaging applications.

For Tomo-PIV the calibration accuracy needs to be better than **0.1** pixel throughout the measurement volume [1, TU-Delft].

Challenge

Camera mounts or other mechanical parts are never 100% stiff. Temperature-changes cause extension or contraction of mechanical parts, wind loads or other vibration sources effect the camera adjustment. Unnoticed, in many experiments, the initial volume calibration will become inaccurate at the time of measurement.

Solution

LaVision's patented* **Volume Self-Calibration** [2, LaVision] allows the detection and correction of calibration inaccuracies using the actual tracer particle recordings. Misalignments are corrected and the required calibration accuracy is recovered.

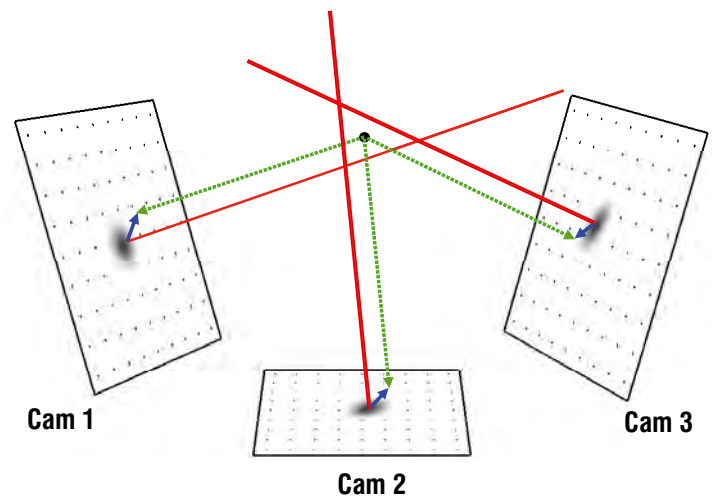

Volume Self-Calibration

Due to inaccuracies in the calibration function, particles in the volume are imaged at slightly offset positions in the camera images. Averaging these differences for many particles in a local sub-volume, 3D disparity maps are generated and the calibration function is corrected accordingly.

This widely accepted Volume Self-Calibration procedure provides a check for and a remedy of possible calibration problems and is **an indispensable pre-processing step for Tomographic PIV.**

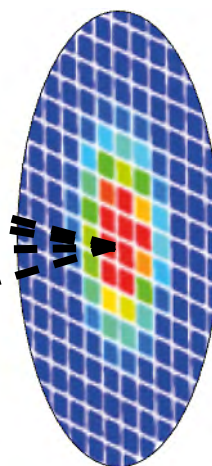

References:

- [1] Elsinga et al., Exp. Fluids 41, 933-947, 2006
- [2] Wieneke, Exp. Fluids 45, 549-556, 2008

* Patents: EP 1 926 049, US 8,120,755



Turbulent fluid motion is the dominating flow configuration for nearly all natural flows as well as for technical applications.

Details of such complex fluid motion can now be quantitatively visualized in 3D (4D) using (time-resolved) Tomo-PIV e. g. for the validation of CFD-codes. Thus Tomo-PIV marks an important step in experimental fluid mechanics research providing insight into previously unseen fluid dynamic phenomena.

Separated flows and turbulent wakes

A high resolution Tomo-PIV system using four 16 Mpixel **Imager LX** cameras captures the turbulent shear layer of a separated flow behind a backward-facing step in a wind tunnel. The instantaneous 3D3C-velocity vector volume includes the complete velocity gradient tensor of the complex flow structure presented by iso-surfaces of 3D-vorticity and one selected vertical velocity plane [1, German Aerospace Center, DLR].

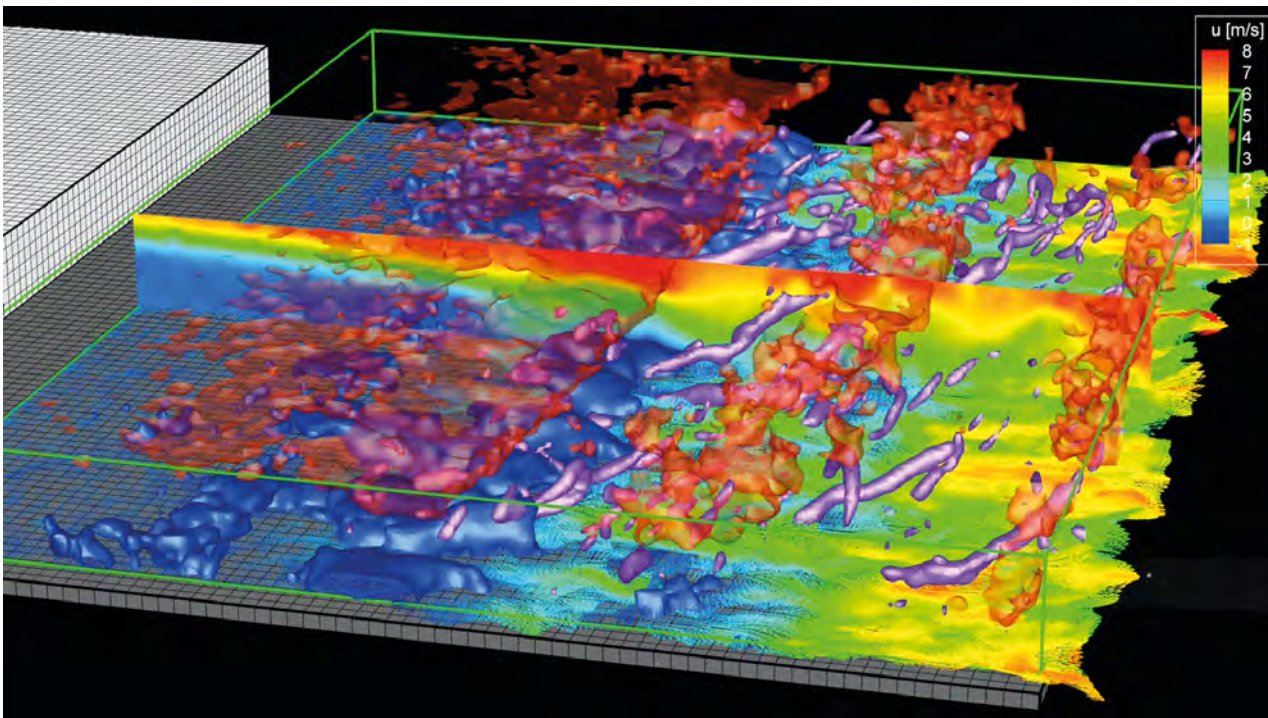
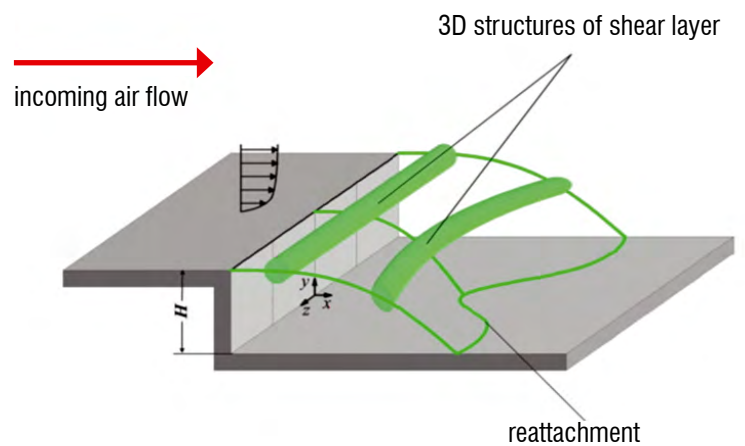

Backward facing step, Tomo-PIV measurement in air

Reference:

[1] Schroeder et al., 9th Int. Symp. PIV Kobe, Japan, 2011



Transitional and turbulent jets

A 3D pattern of a transitional water jet flow is recorded using time-resolved Tomo-PIV at 1kHz frame rate. Iso-surfaces of vorticity using the Q-criterion and an axial velocity plane within the 3D measurement volume are presented [2, TU-Delft].

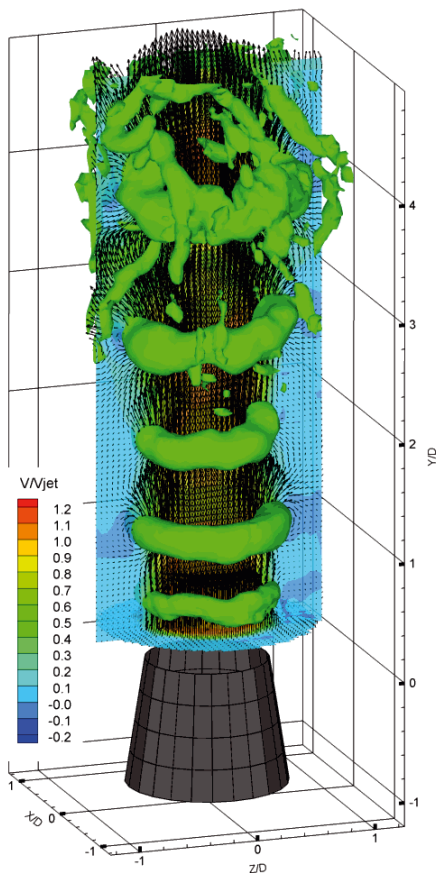

Vortex dynamics studies in a cylinder wake. Tomo-PIV reveals the details of the coherent structures in the turbulent wake of a cylinder and describes both velocity and vorticity fluctuations when time-resolved measurements are applied [1, TU-Delft].

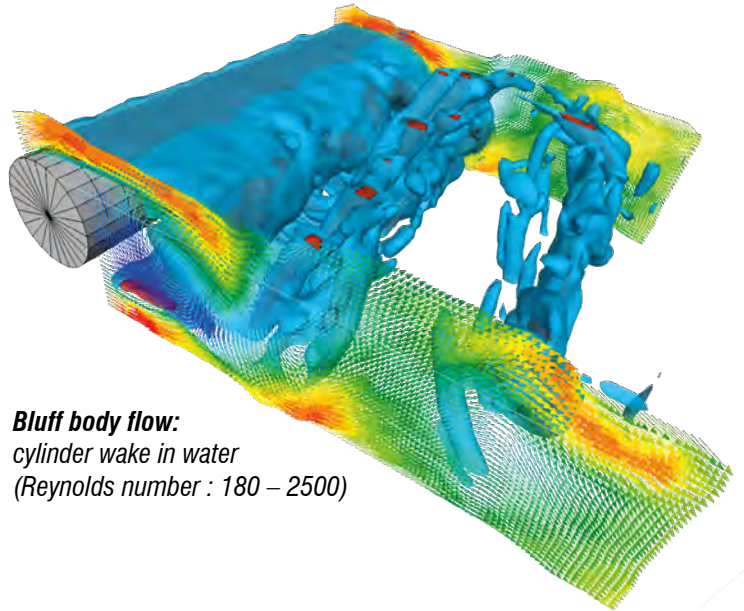

Bluff body flow:
cylinder wake in water
(Reynolds number : 180 – 2500)

2 camera Tomo-PIV

Applying the new reconstruction method **Motion Tracking Enhancement (MTE)** for time-resolved recordings a reduced 2 camera setup already enables Tomo-PIV measurements.

This approach allows the direct migration from Stereo-PIV (2D3C) to full volumetric Tomo-PIV measurements (3D3C).

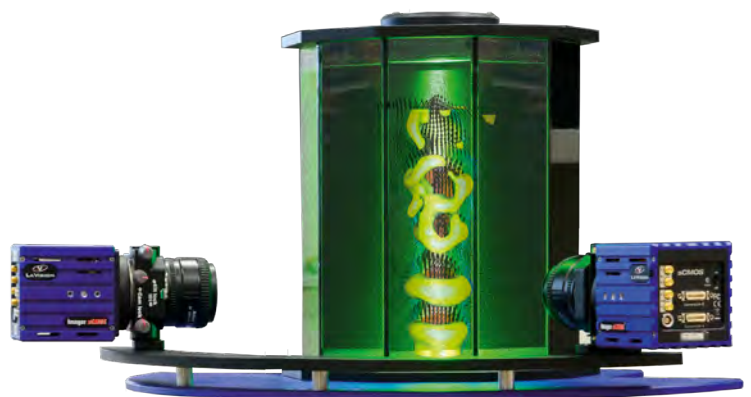

2-camera Tomo-PIV setup

References:

- [1] Scarano et al., Exp. Fluids 47, 69-83, 2009
- [2] Scarano et al., 15th Int. Symp. Applications of Laser Techniques to Fluid Mechanics, Lisbon, Portugal, 2010

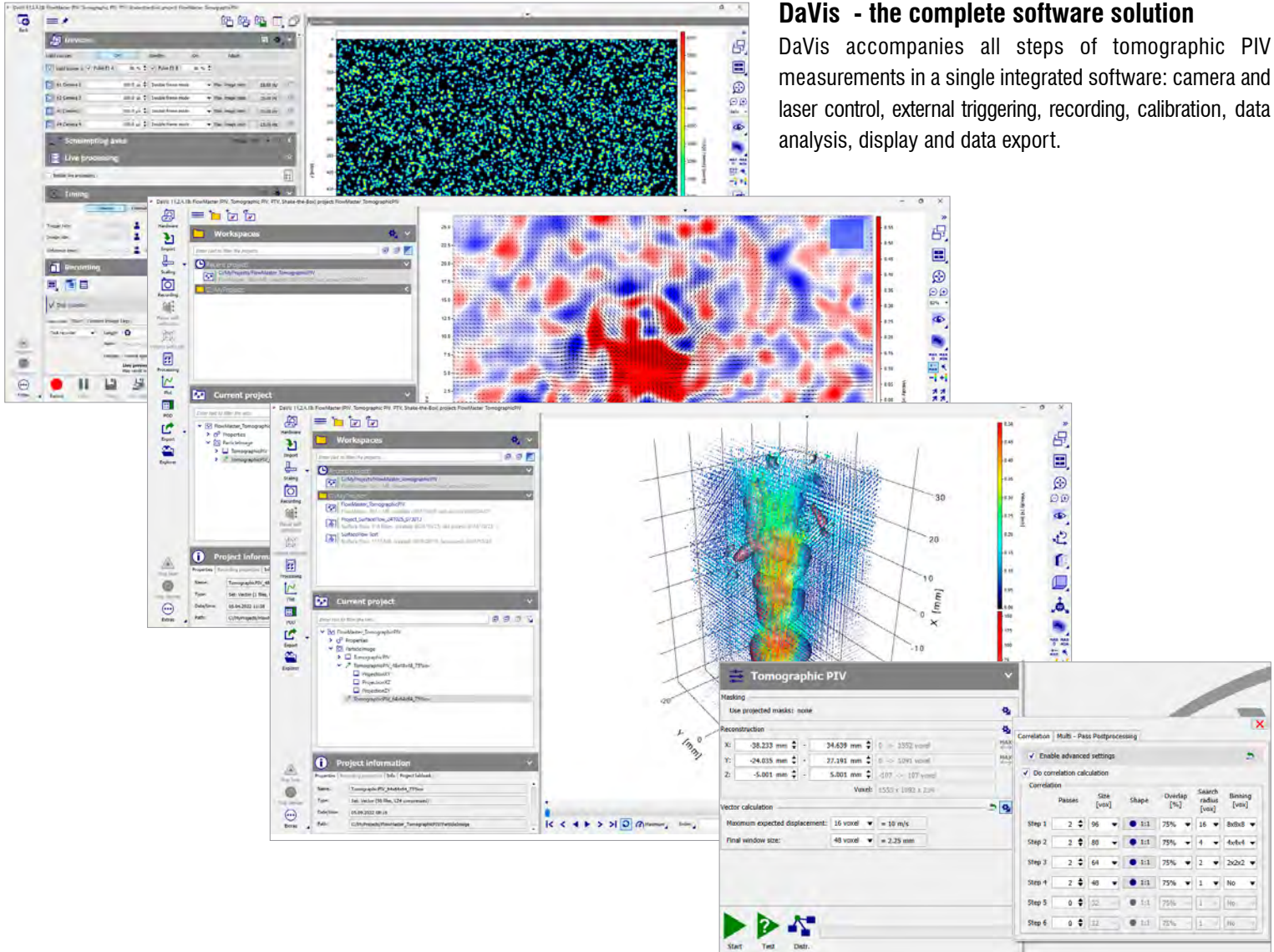

DaVis - the complete software solution
DaVis accompanies all steps of tomographic PIV measurements in a single integrated software: camera and laser control, external triggering, recording, calibration, data analysis, display and data export.

Versatile hardware synchronization

DaVis controls up to 8 fully synchronized PIV cameras and 4 lasers, ranging from simple time-based trigger schemes to phase locked measurements and time-resolved recording.

Open Data Access

DaVis provides free interfaces to Matlab® (also on Mac OS® and Linux®), Tecplot® and a C++ library for own code developments.

Image and 3D-vector post-processing

Making use of true 64 bit architecture, DaVis processes large volume data on multi-core CPUs and massively accelerated on GPUs. You can build up own processing lists and combine operations steps from a comprehensive range of vector statistics, derivatives and scalar operations.

Data management and traceability

With the built in processing history, you are able to reveal recording settings and previous processing steps to keep track on your data's history. The project manager keeps all camera images, the calibration and processing results in a manageable structure.

Tomo PIV patent filed	First paper	MART FFT Correlation	Volume Self Calibration	Motion Tracking Enhancement
2003	2006	2007	2008	2009

DaVis Tomo-PIV: an ongoing process of innovations

The first publication in 2006 triggered a real gold rush in the scientific community.

This rush is best documented by the ever growing number of publications, dealing with the development and, more and more, with the application of tomographic PIV. Taking an active part in the ongoing process of innovation, our strategy is to make the benefits of innovation available in the easy-to-use environment of **DaVis**.

Major milestones in this innovative process, that directly found their way in the **DaVis** software, include:

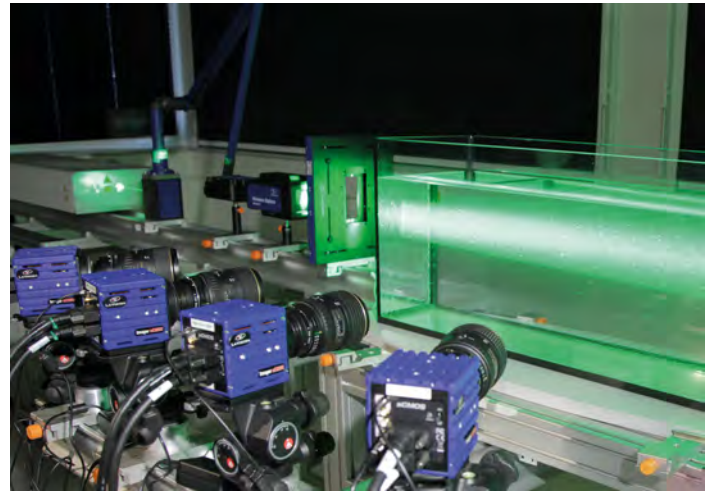

- ▶ **Robust volume reconstruction algorithm:** MART (Multiplicative Algebraic Reconstruction Technique)
- ▶ **Multistep correlation with deformed interrogation volumes** (FFT correlation in 3D)
- ▶ **Validation and correction of the volume calibration** (Volume Self-Calibration)
- ▶ **Reconstruction quality improvement** by ghost intensity reduction, allowing 2 camera Tomo-PIV systems (Motion Tracking Enhancement, MTE)
- ▶ **Significant reduction of computation time** using sparse reconstruction and direct correlation
- ▶ **Robust Tomo-PIV in situations with obstacles and reflections** (advanced volume masking)
- ▶ **Taking advantage of time-resolved data** for significant noise reduction and the calculation of acceleration (Fluid Trajectory Correlation, similar to sliding sum of correlation)
- ▶ **Adapting Tomo-PIV to difficult imaging conditions** like astigmatism, blurred particles (Optical Transfer Function, OTF [1, German Aerospace Center, DLR]*)
- ▶ **Lagrangian particle tracking at highest seeding densities**, omitting voxel-volume reconstruction and correlation (Iterative Particle Reconstruction, IPR [2, LaVision]** and “Shake the Box” algorithm [3, German Aerospace Center, DLR]***)

References:

- [1] Schanz et al. (2013) Meas. Sci. Technol. 24 024009
- [2] Wieneke B (2013) Meas. Sci. Technol. 24 024008
- [3] Schanz et al. 10th Int. Symp. on PIV, 2013, Delft, The Netherlands

* Patent EP 2494522A1, US 20120274746

** Patent EP 2344894A1, US 20110299738

*** Patent DE 10 2013 105 648

Fast MART
Fast Direct Correlation

Advanced Volume
Masking

Fluid Trajectory
Correlation

Optical Transfer
Function

Shake-the-Box

2011

2013

2014

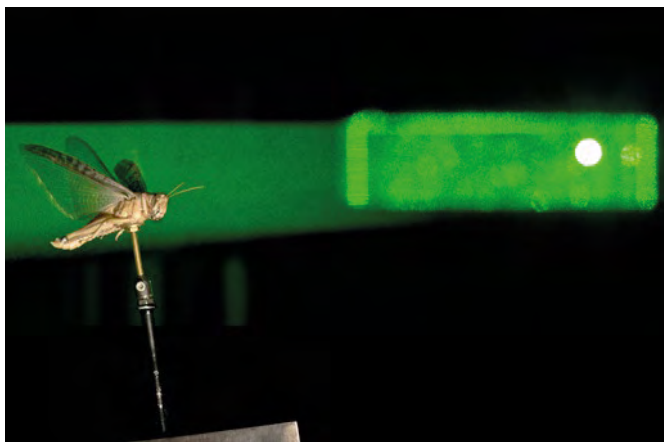

Aerodynamic wake flow of a flying locust

Volumetric flow imaging is a major step forward in our understanding of turbulent flows induced by flying animals and thereby the mechanics of their locomotion.

Animal flight cannot be captured time averaged. Time-resolved recordings with synchronized high-speed cameras are essential to reveal the full space-time information.

Time-resolved Tomo-PIV measurements are applied in the wake flow of a tethered locust flying in a wind tunnel at a wind speed of 3.3 m/s. The Tomo-PIV imaging system consists of 4 high-speed cameras (**HighSpeedStar 3G**) synchronized with a 1 kHz high-speed laser. [1, University of Oxford].



Using most sensitive **Imager sCMOS** cameras, the complete instantaneous vortex wake structure of a flying desert locust is measured. Iso-surfaces of clockwise and counter clockwise rotating vortices as well as the downwash are presented.

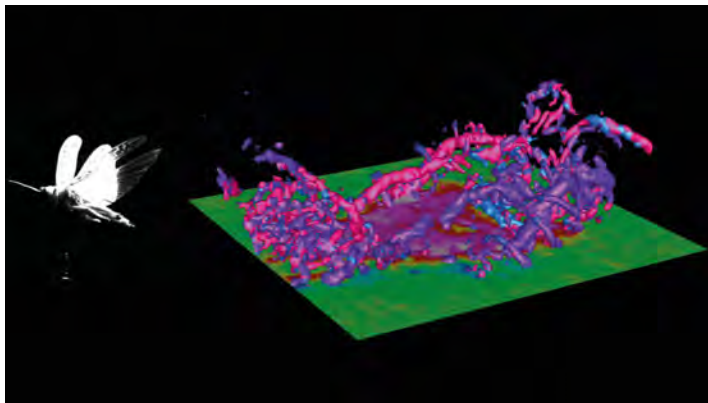

Reference:

[1] Bomphrey et al., J. R. Soc. Interface 9, 3378-3386, 2012



Hydrodynamic footprint of a swimming Daphnia

The hydrodynamic footprint of small swimming organisms such as the zooplankton Daphnia is – although small in size – affecting the ecosystem in many ways like feeding strategies and local water transport.

The hydrodynamic trails of a freely swimming Daphnia in still water are successfully investigated applying time-resolved Tomo-PIV [1, LaVision].

2 mm large Daphnia

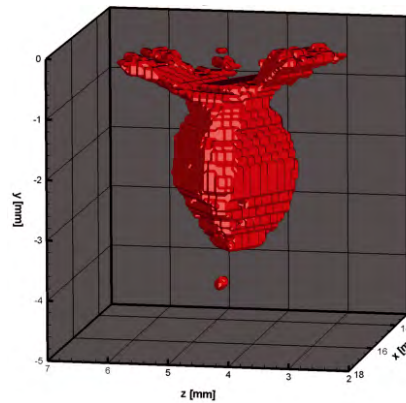
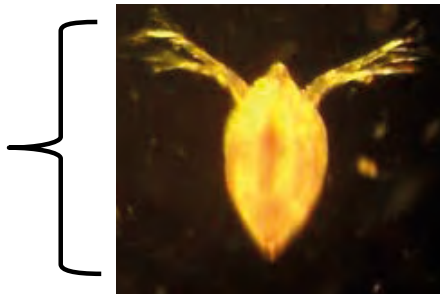

3D reconstruction of swimming Daphnia

The turbulent and time-resolved flow fields of an upward swimming Daphnia in a test aquarium are recorded using four 5 Mpixel **Imager SX 5M** cameras.

Apparently, hydrodynamic trails of a swimming Daphnia can be many times larger than the size of the organism itself (see also back page).

This work was carried out in cooperation with the **University Koblenz-Landau**

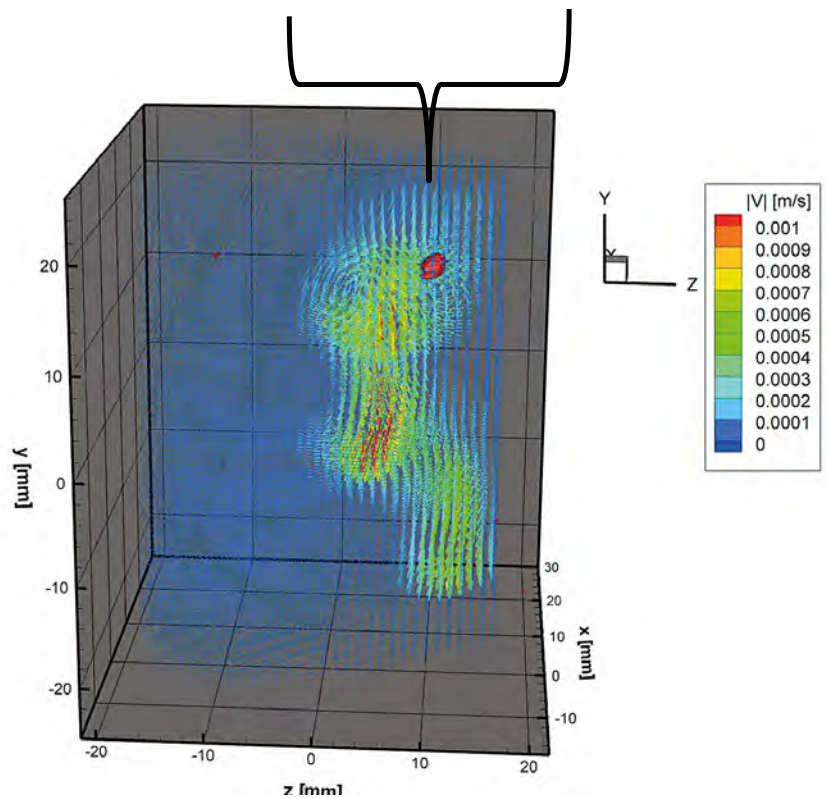

Reference:

[1] Michaelis, 16th Int. Symp. on Flow Visualization, Okinawa, Japan, 2014

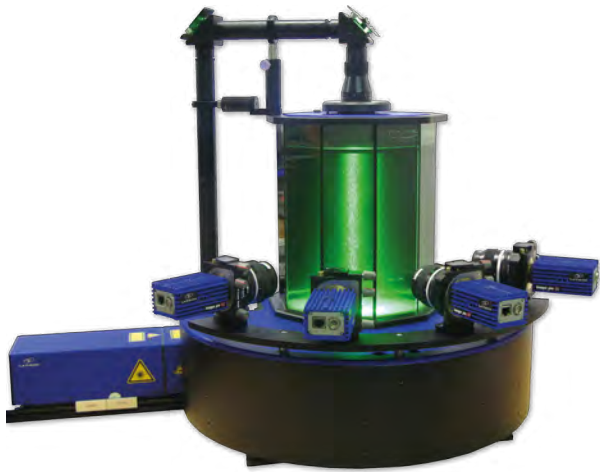

Modular and upgradable Tomo-PIV solutions

LaVision provides a complete range of flexible and modular Tomo-PIV systems and components for an integrated “easy to use” Tomographic PIV solution for your application.

Tomo-PIV measurements are already possible with a two camera Stereo-PIV system. Each additional camera added to the system increases the achievable spatial resolution exposing 3D flow structure in more detail.



From flow illumination to 3D3C flow field data

Laser

- ▶ Same standard laser used in traditional PIV systems
- ▶ Low repetition rate: large volumes, small seeding particles
- ▶ High repetition rate: time-resolved 4D flow field imaging

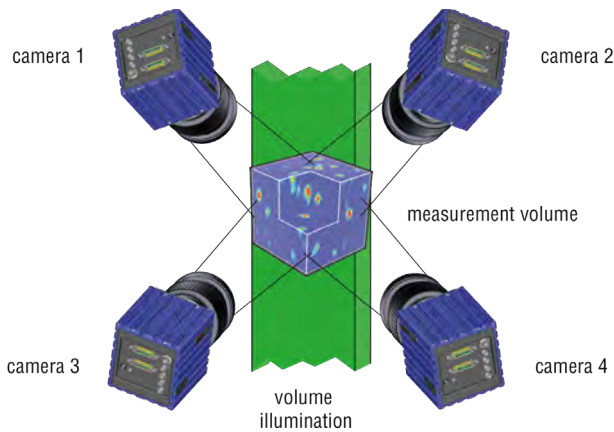

Cameras

- ▶ All LaVision camera models are supported
- ▶ **Imager sCMOS** for high resolution and highest sensitivity
- ▶ 2–8 camera imaging systems possible
- ▶ Straightforward upgrade from 2 up to 8 cameras

Volume Illumination Optics

- ▶ Collimated illumination up to 50 x 100 mm²
- ▶ Adjustable divergent optics for larger volumes
- ▶ Higher illumination levels with multi-pass arrangements

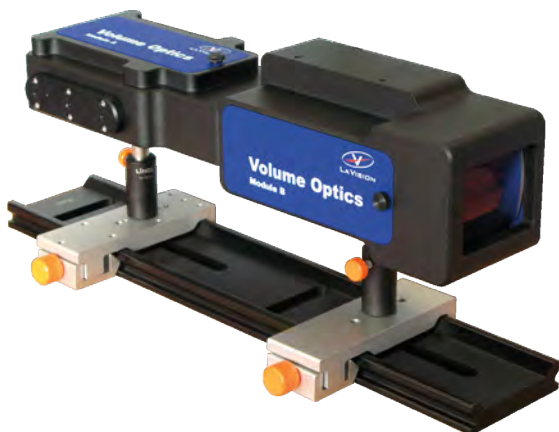



FlowMaster Tomo-PIV main performance features:

- ▶ 3D imaging system with highest spatial resolution powered by advanced MART algorithms and Volume Self-Calibration
- ▶ Suitable for measurements in low- and high-speed flows and for time-resolved recordings for 4D flow analysis
- ▶ Upgradable and versatile multi camera imaging concept

Camera Scheimpflug Adapters for Oblique Viewing

- ▶ Independent adjustment for Scheimpflug angle and optical axis
- ▶ Motorized and software controlled models
- ▶ Rigid construction supporting sub-pixel imaging w/o jiggling



3D Calibration Targets

- ▶ Highly accurate double-sided calibration targets
- ▶ Single view calibration, **no scanning**
- ▶ Calibration active on both sides
- ▶ One target position sufficient for volume calibration

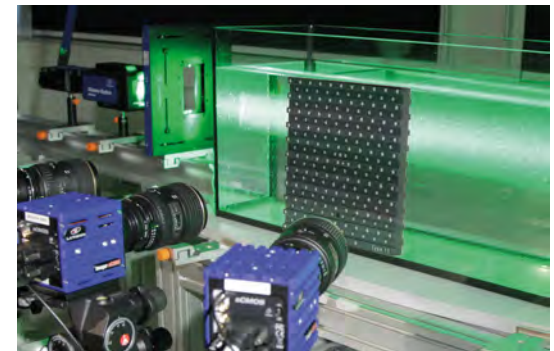

Synchronizer and Timing Unit

- ▶ Multi-channel **Programmable Timing Unit (PTU)**
- ▶ Versatile combination of low- and high-speed lasers and multiple cameras
- ▶ Precise synchronization even for varying external triggers
- ▶ Designed for demanding experiments with complex trigger schemes
- ▶ Fully integrated device trigger generation in **DaVis**
- ▶ Software controlled PIV-dt and phase scans



DaVis Tomo-PIV Software Package

- ▶ State-of-the-art tomographic reconstruction algorithm combined with advanced voxel correlation strategies
- ▶ Highest reconstruction quality with patented **Volume Self Calibration**
- ▶ Massive parallel processing: support of GPU and multi-processor PCs
- ▶ Powerful post-processing and 3D display features incl. avi-movies
- ▶ Fast preview mode
- ▶ Upgradable from the universal **DaVis FlowMaster** PIV package
- ▶ TecPlot® Add-on for outstanding 3D visualization



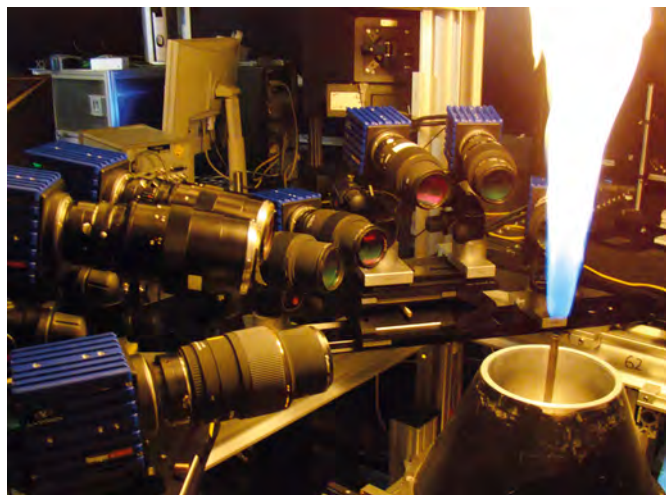

3D Flame structure and turbulence-flame interaction

3D (Laser) Imaging in flames improves our understanding of combustion processes and thus the realization of more efficient and cleaner combustion devices. The 3D distribution of flame radicals mainly located in the reaction zones is visualized using 3D reconstruction of multiple camera views and turbulence–flame interaction in combination with Tomo-PIV [1,2, TU-Darmstadt].

While eight 5.5 Mpixel **Imager sCMOS** cameras are used in parallel to reconstruct the instantaneous 3D flame structure shown to the right, time-averaged 3D flame imaging is possible with only one camera collecting consecutively the flame emission from multiple viewing angles.

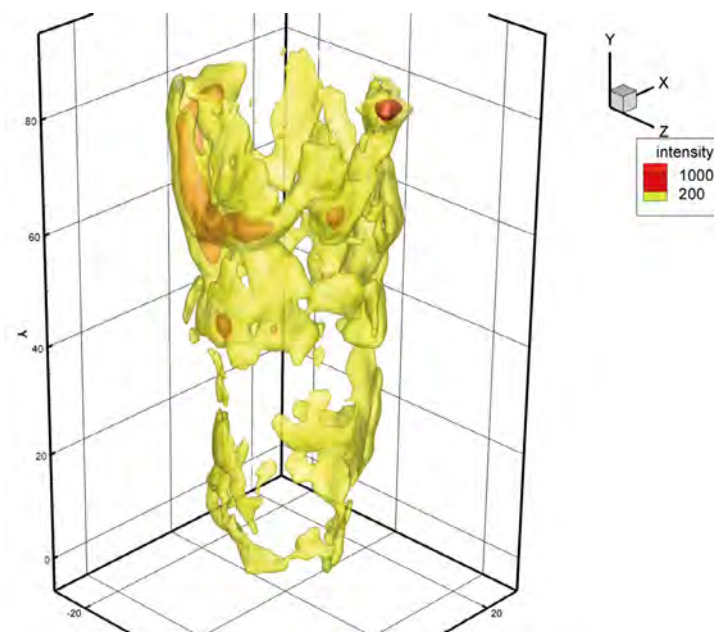

The presented 3D flow field of the flame below is recorded with a 4 camera Tomo-PIV system using TiO_2 seeding particles

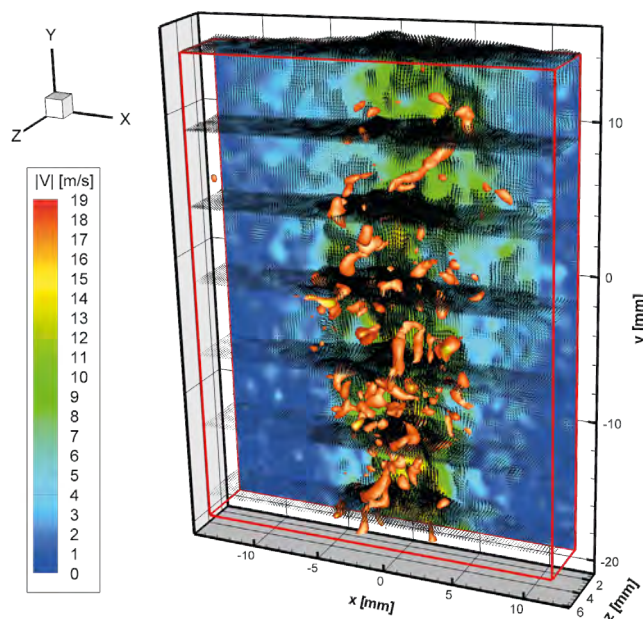

References:

- [1] Weinkauff et al., 17th Int. Symp. on Applications of Laser Techniques to Fluid Mechanics, Lisbon, 2014
- [2] Weinkauff et al., Exp. Fluids 54, 2013

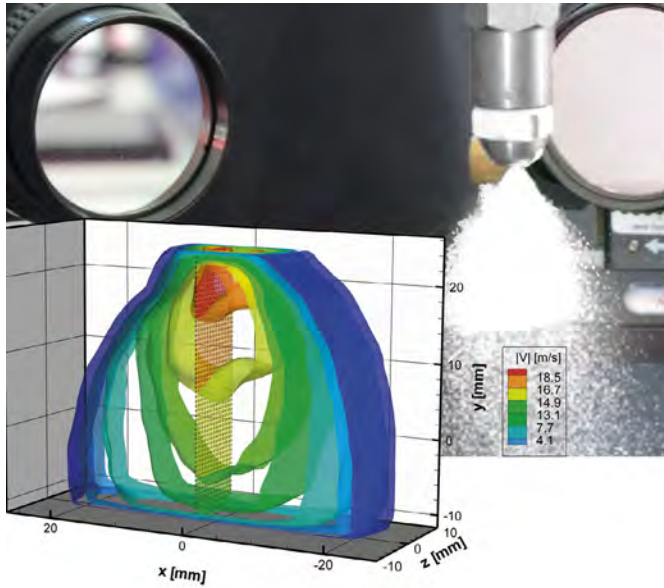

Volumetric spray velocimetry

For many spray processes the knowledge about the spatial distribution of the droplet velocities within the multiphase flow is of utmost importance especially for unsteady and highly dynamic sprays. For such spray investigations only Tomo-PIV applied on spray droplets can measure the 3D spray structure of droplet motion in an instant.

Using multiple camera views the droplet positions are reconstructed in 3D space. From such time-correlated 3D spray images the instantaneous volumetric droplet flow field is derived together with its 3D vortex structure enabling 3D spray characterization in all details.

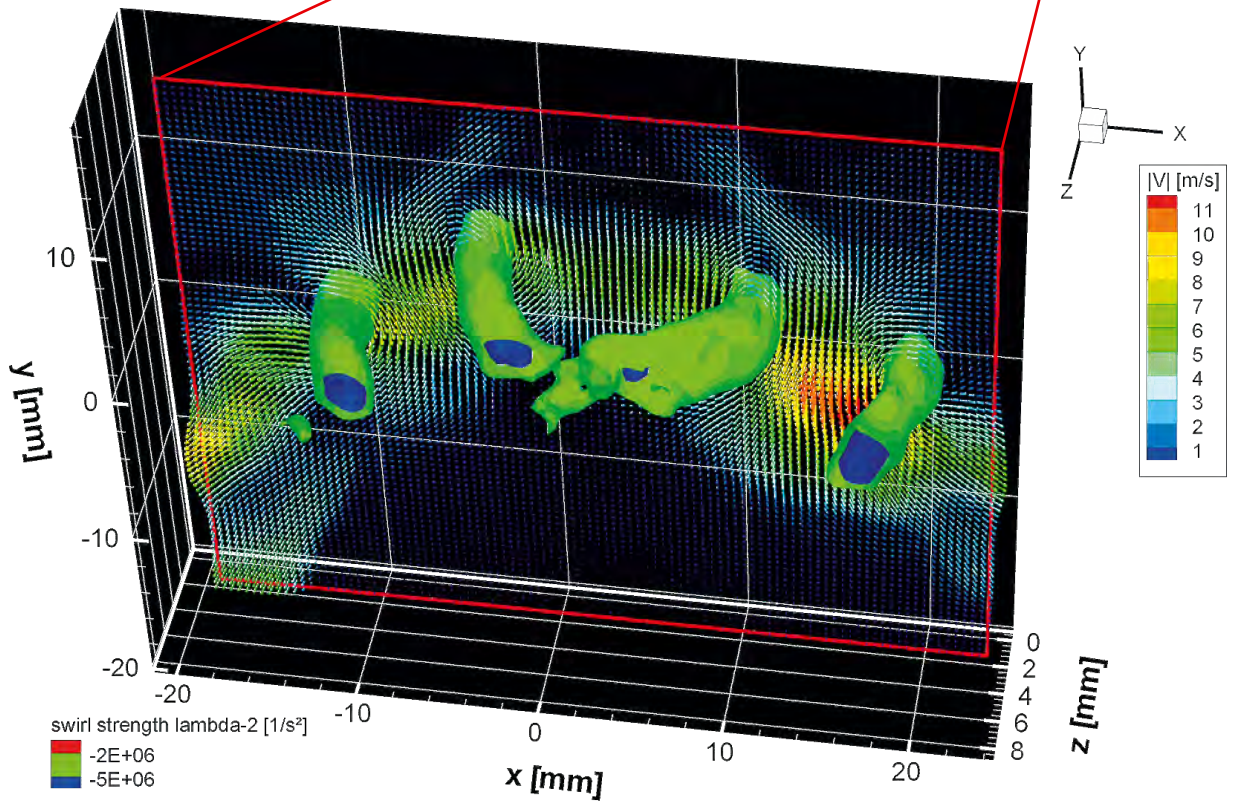
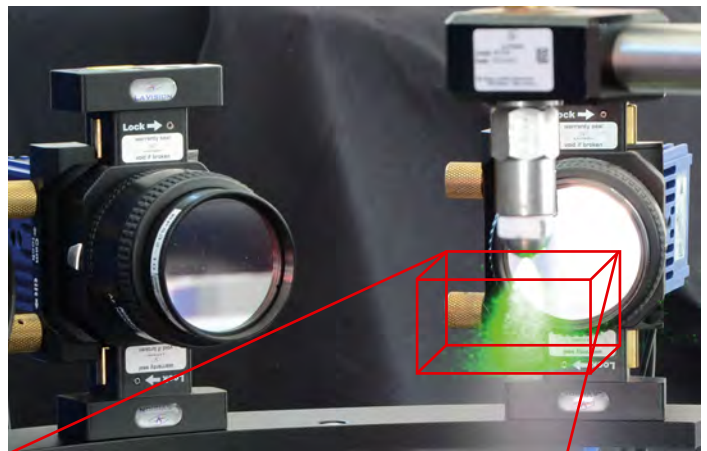



Propeller wake analysis

The knowledge of the mechanisms of wake instability behind rotor systems, such as propellers, wind turbines or helicopter rotors, plays an important role in many engineering applications, because of its direct correlation to performance, vibrations, noise and structural problems. Tomo-PIV represents a very effective tool for instant flow based analysis as, for example, to study the three dimensional and turbulent dynamics of the propeller tip vortices in the transition and far fields.

Tomographic PIV experiments are performed in the cavitation tunnel of CNR-INSEAN on a 220 mm in diameter propeller model for wake analysis using a double-cavity Nd:YAG laser and four **Imager sCMOS** cameras (5.5 Mpixel).

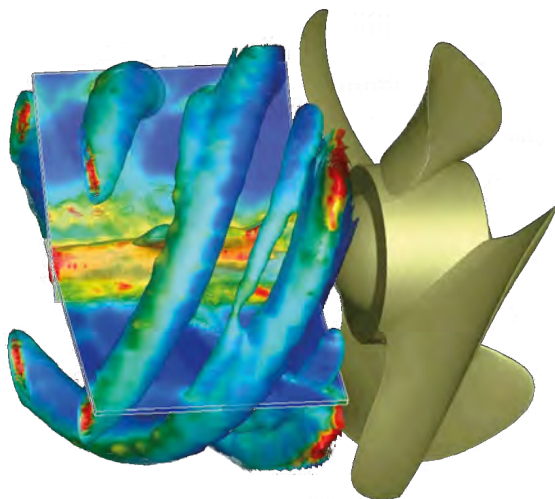
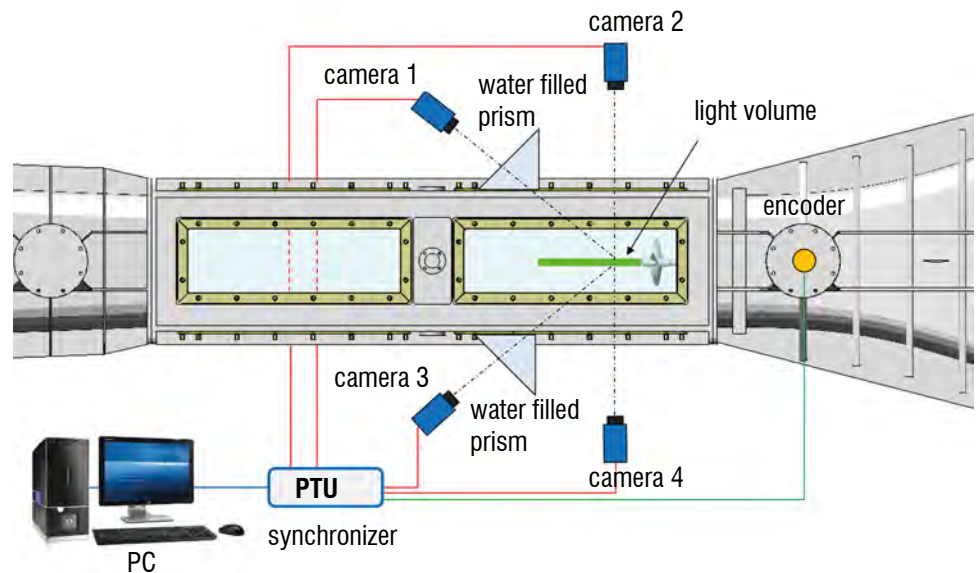

Propeller induced 3D flow field

3D vortex structure in the propeller wake

Presented in the figure are slices and iso-surfaces colored with the azimuthal component of the vorticity in the near field of the propeller wake. Iso-surfaces, defined using the λ_2 criterion, highlight the coiling mechanism of a secondary filament around the tip vortex.

Courtesy of M. Felli & M. Falchi,
CNR-INSEAN

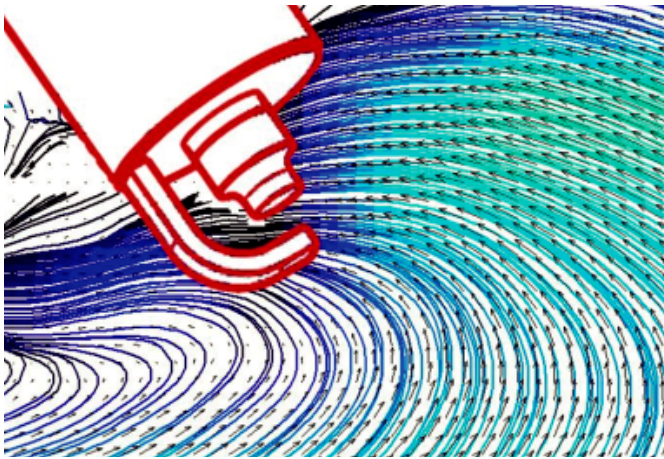
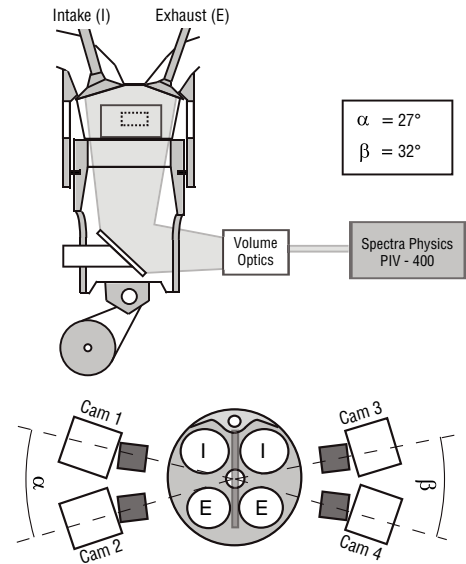
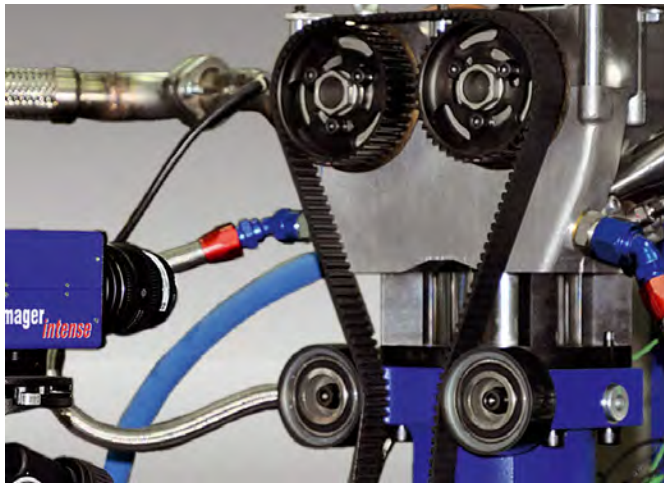

Image courtesy of KIT (IFKM)

In-cylinder 3D flow fields

Knowledge of in-cylinder flow motion is essential for the design of modern IC-engines exhibiting improved efficiencies and reduced emissions.

Four 1.4 Mpixel **Imager intense** cameras are detecting in a time-correlated double exposure mode the movement of oil droplets seeded into the in-cylinder air. The measurement volume is illuminated with a double-pulse Nd:YAG laser enabling Tomo-PIV measurements.



In-cylinder 3D tumble motion

Volume Self-Calibration is applied and corrects for any influence of engine vibrations providing a high level of reconstruction quality (camera misalignment < 0.3 pixel).

The crank angle resolved (270° bTDC) cycle averaged 3D flow field in the tumble plane is presented showing iso-surfaces of velocity magnitude. The 3D structure of the tumble vortex is clearly seen [1, TU-Darmstadt].

Reference:

[1] Baum et al., Flow Turbulence Combustion 92, 269-297, 2014

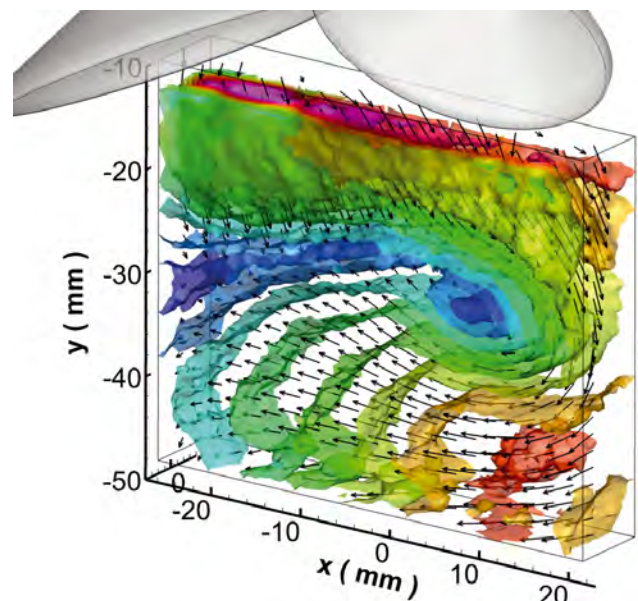

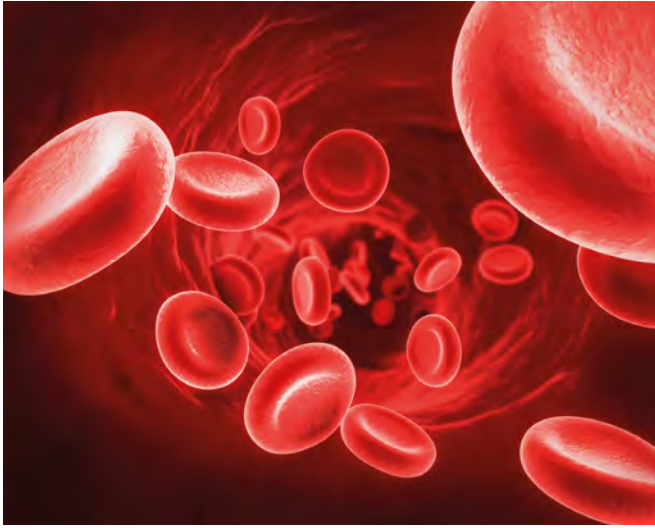

3D blood flow visualization

Coronary artery diseases are the leading cause of death in the developed world and are dependent on the 3D blood flow structure and shear wall stress within the blood vessels. Tomo-PIV is successfully applied to investigate in vitro flow and wall shear stress in realistic coronary artery models.

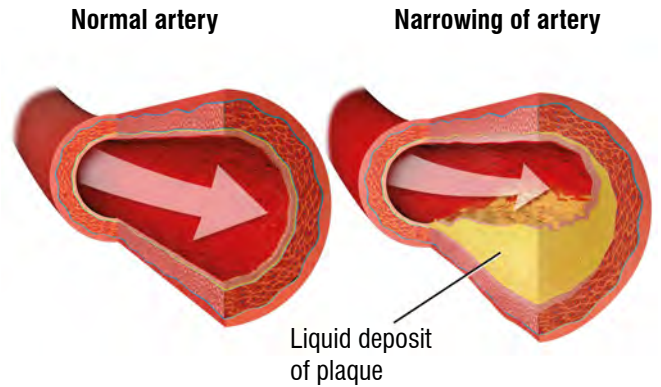

Distortion-free imaging applying refractive index matching

In vitro blood flow Tomo-PIV measurements are carried out using a silicone phantom simulating a human blood artery. The work fluid is a silicone-water mixture approximating the viscosity and density of human blood.

This fluid is also filled in the test section surrounding the silicone model to eliminate image distortion effects caused by refractive index changes in the different media.

no index matching

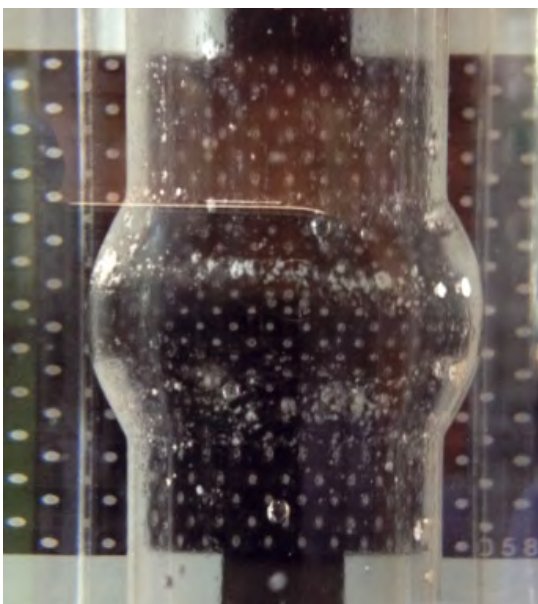

with index matching fluid



fluorescent particle image

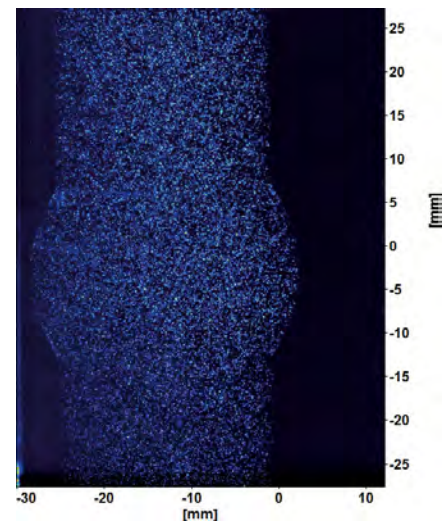

3D flow structure in a human carotid artery

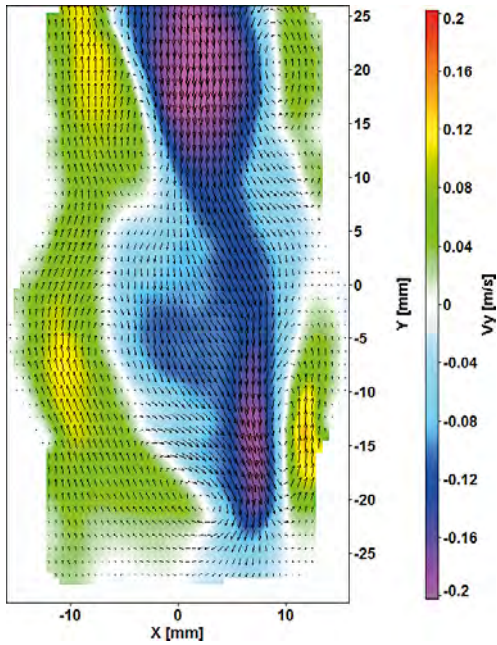

Blood flow velocity in an axial plane, the y-component is color-coded.

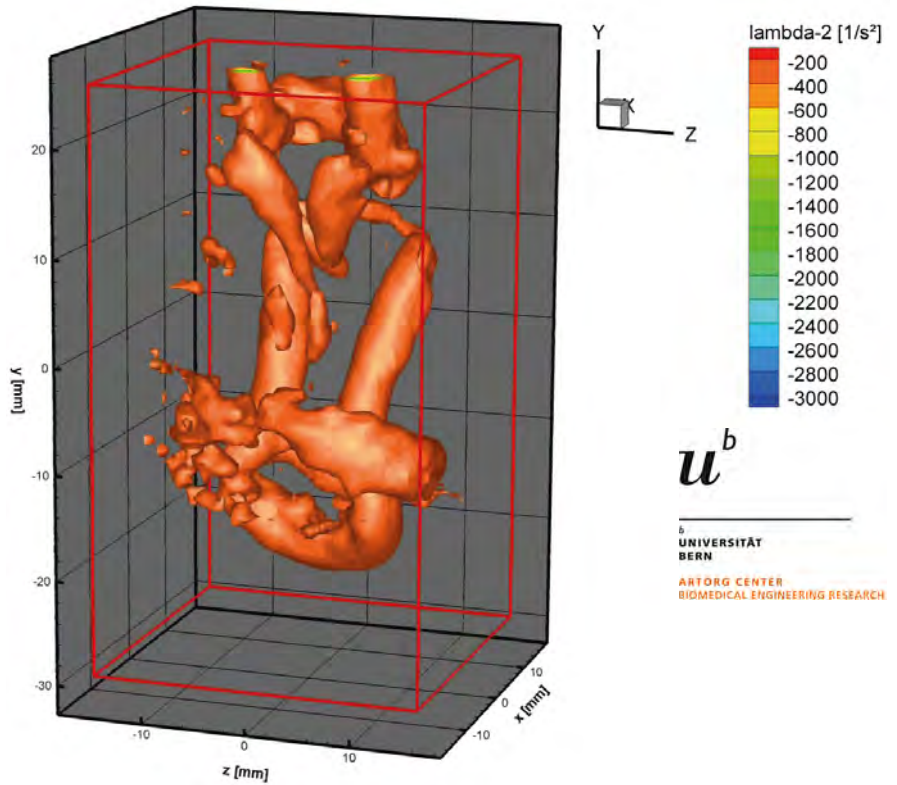

Iso-surfaces of vortex core of the blood flow is presented.

Courtesy of D. Obrist
University of Bern

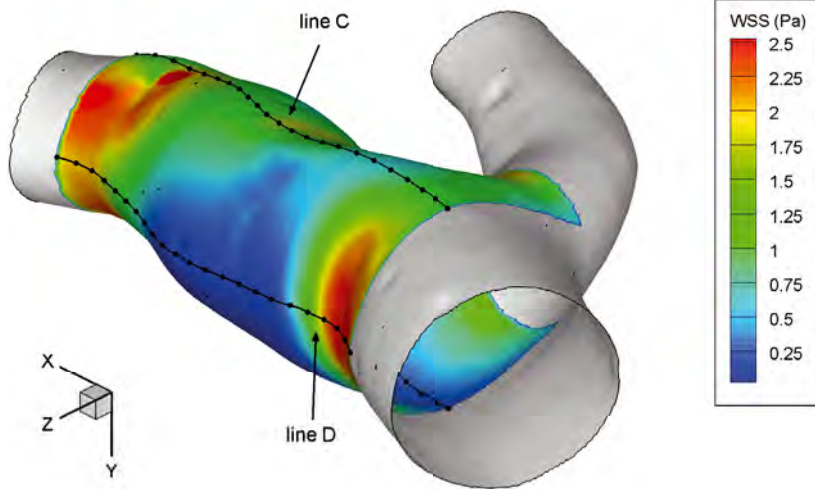

Wall shear stress in an artery

The presented wall shear stress in a realistic human carotid artery bifurcation is calculated from 3D velocity fields recorded with a 4 camera Tomo-PIV system. The flow is seeded with 20 μm hollow glass spheres [1, University of Canterbury, NZ].

Reference:

[1] Buchmann et al., 8th Int. Symp. PIV Melbourne, Australia, 2009

The Dynamics of Swimming on Small Scales

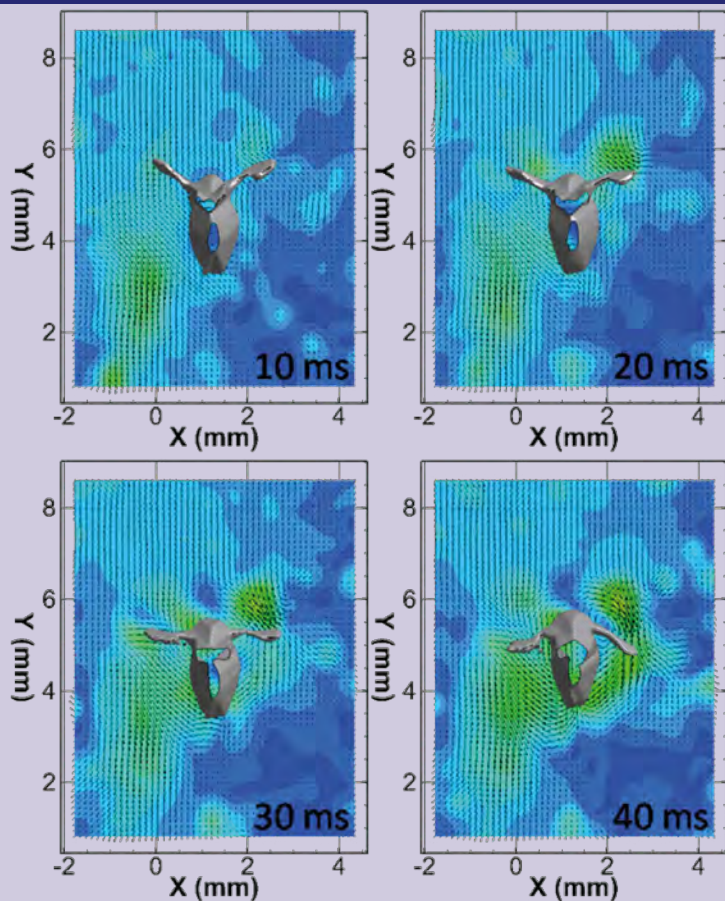

On small scales, viscous forces in the surrounding water become more dominant for the dynamics of swimming for the 2 mm small Daphnia, which produces a complex structure of vortices on its trail. The flow field around this animal is affected by its motion even at a far distance compared to its size in all 3 dimensions.

LaVision's Tomo-PIV algorithm reconstructs the flow field at a spatial resolution of 0.2 mm but also the Daphnia itself: the body's surface in the image is a direct result from the tomographic reconstruction.

Courtesy of D.W. Murphy
Ph.D. thesis, 2012
Georgia Institute of Technology, Atlanta

Measurement Volumes in Tomographic PIV Experiments

	Pulse energy (mJ)	Volume (mm ³)	Tracer particles
Low-rep rate, air	800	200 x 200 x 50	1 μ m oil droplets
Low-rep rate, water	200	120 x 120 x 60	50 μ m polyamide
High-speed (5 kHz), air	20	34 x 30 x 19	1 μ m oil droplets
High-speed (2 kHz), air	20	220 x 220 x 100	Helium bubbles
High-speed (1 kHz), water	22.5	170 x 100 x 80	100 μ m silver coated particles

LaVisionUK Ltd

2 Minton Place / Victoria Road
Bicester / Oxon / OX26 6QB / United Kingdom
E-Mail: sales@lavisisionuk.com
www.lavisisionuk.com
Phone: +44-(0)-870-997-6532
Fax: +44-(0)-870-762-6252

LaVision GmbH

Anna-Vandenhoeck-Ring 19
37081 Göttingen / Germany
E-Mail: info@lavisision.com
www.lavisision.com
Tel.: +49-(0)5 51-9004-0
Fax: +49-(0)551-9004-100

LaVision Inc.

211 W. Michigan Ave. / Suite 100
Ypsilanti, MI 48197 / USA
E-Mail: sales@lavisisioninc.com
www.lavisision.com
Phone: (734) 485 - 0913
Fax: (240) 465 - 4306