



Product-Manual

Phantom Miro M-series

Item-Number(s): 1102200/01/02, 1102210/11/12, 1102220/21/22



Product-Manual for **DaVis** 8.3

LaVision GmbH, Anna-Vandenhoeck-Ring 19, D-37081 Göttingen

Produced by LaVision GmbH, Göttingen

Printed in Germany

Göttingen, June 19, 2015

Document name: 1007794_Phantom_M_series_D83.pdf

Contents

1 Safety Precautions	5
1.1 Laser Safety	5
1.2 Seizures Warning	6
1.3 Camera / Image Intensifier Safety	7
2 Network Interface Card (NIC) Configuration	9
2.1 Interface Configuration	9
3 Phantom Miro M-series	15
3.1 Important Safety Instructions	15
3.2 General	15
3.3 Installation	15
3.4 Temperature	16
3.5 Storage	16
3.6 Shipping	16
3.7 Precautions	16
3.8 FCC Declaration Not Obligatory for CE	16
3.9 Phantom Miro M-series Specifications	17
3.10 Spectral Response Curves	18
3.11 Camera Connectors and Indicators	19
3.12 Camera Connector	20
3.13 Status LEDs	23
3.13.1 Power Indicator	23
3.13.2 Capture Indicator	23
3.13.3 Communication Indicator	23
3.13.4 Ethernet Activity Indicator	24
3.13.5 Ethernet Link Indicator	24
3.14 Dimensions	25
4 Phantom Wiring	27
4.1 Installing the Network Interface Board	27
4.2 Cabling and Connections	27
4.2.1 Wiring with one Phantom camera	27

4.2.2	Wiring with two Phantom cameras	30
5	Hardware Setup	33
6	Device Settings	35
6.1	Camera: Phantom	35
6.1.1	Scales and Overlays	36
6.1.2	Active Image Correction	36
6.1.3	Image Transformation	37
6.1.4	Intensity correction	38
6.1.5	Image Area Data	39
7	Troubleshooting	41
7.1	Camera Serial Number not registered	41
7.2	Camera cannot be initialized by DaVis	41
7.3	The camera shows no live images on Take/Grab	41
7.4	Reset the camera to factory default	42
8	Customer Service	45
8.1	Order and Dongle Number	45
8.2	Customer Settings	46
8.3	Log file	47
8.4	Export data set for support	48
8.5	Camera Activity Logging	50
8.6	Shipment of defective items	52

1 Safety Precautions

Before working with your **LaVision** system we recommend to read the following safety precautions. Observing these instructions helps to avoid danger, to reduce repair costs and downtimes and to increase the reliability and life of your **LaVision** system.

1.1 Laser Safety

If a laser¹ is integrated in your system it is important that every person working with it has fully read and understood these safety precautions **and** the laser manual of the specific laser.

Lasers included in **LaVision** systems may belong to CLASS 4 laser devices, which are capable of emitting levels of both visible and invisible radiation that can cause damage to the eyes and skin. It is absolutely necessary that protective eyewear with a sufficiently high optical density is worn at any time when operating the laser. The goggles must protect against all wavelengths that can be emitted, including harmonics. See your Laser's manual for further details.

Class 4 laser beams are by definition a safety and fire hazard. The use of controls, adjustments or performance of procedures other than those specified in the **LaVision** manual and laser manual may result in hazardous radiation exposure.

AVOID EYE AND SKIN EXPOSURE TO DIRECT OR SCATTERED RADIATION. FOLLOW THE INSTRUCTIONS YOU CAN FIND IN THE CORRESPONDING LASER MANUAL FOR PROPER INSTALLATION AND SAFE OPERATION. USE PROTECTIVE EYE WEAR ALL THE TIME WHEN OPERATING THE LASER.



Important instructions for safe laser handling:

- Before operating the laser contact your laser safety officer.

¹In the following 'laser' means any kind of laser, in particular Nd:YAG- and dye laser as well as Optical Parametric Oscillators at any wave-length and output-energy.

- Read and understand the instruction manual of the particular type of laser. Take special care with respect to laser emission, high voltage and hazardous gases if in use.
- Declare a controlled access area for laser operation. Limit access to trained people. Never operate the laser in a room where laser light can escape through windows or doors. If possible, cover beam paths to avoid obstacles getting into the beam.
- Provide adequate and proper laser safety-goggles to **all** persons present who may be exposed to laser light. The selection of the goggles depends on the energy and the wavelength of the laser beam as well as the operation conditions. Check the Laser's manual for a detailed description.
- While working with lasers do not wear reflective jewelry like watches and rings, as these might cause accidental hazardous reflections.
- Avoid looking at the output beam, even diffuse reflections can be dangerous.
- Operate the laser at the lowest beam intensity possible.
- Avoid blocking the output beam or reflections with any part of the body. Use beam dumps to avoid reflections from the target.
- Wear clothes and gloves which cover arms and hands to avoid skin damage when handling in the optical path. Especially UV-radiation can cause skin cancer.



1.2 Seizures Warning

WARNING: HEALTH HAZARD! STROBE LIGHTING COULD TRIGGER SEIZURES
Some people (about 1 in 4000) may have seizures or blackouts triggered by flashing lights or patterns. This may occur when viewing stroboscopic lights or objects illuminated by such devices, even if a seizure has never been previously experienced. Anyone who has had a seizure, loss of awareness, or other symptoms linked to an epileptic condition should consult a doctor before operating systems which include flashing lights, strobe lights, or a pulsed or modulated laser.

Stop operating the system immediately and consult a doctor if you have one of the following symptoms:

- convulsions, eye or muscle twitching, loss of awareness, altered vision, involuntary movements, disorientation

To reduce the likelihood of a seizure when operating a system:

- Do not look directly at flashing light sources or on illuminated objects, e.g. into a strobe light or a flashing LED panel.
- Operate the system in a well-lit room.
- Take frequent breaks in normally illuminated areas.

1.3 Camera / Image Intensifier Safety

The camera integrated in your system is based on a CCD (Charge Coupled Device) or CMOS (Complementary Metal-Oxide Semiconductor) sensor with high resolution and high sensitivity. Optionally your system is equipped with a built-in or external image intensifier.

A LASER BEAM FOCUSED ON THE CHIP OR INTENSIFIER, EITHER DIRECTLY OR BY REFLECTION, CAN CAUSE PERMANENT DAMAGE TO THE CHIP OR INTENSIFIER. ANY LASER POWERFUL ENOUGH TO PRODUCE LOCALIZED HEATING AT THE SURFACE OF THE CHIP OR INTENSIFIER WILL CAUSE DAMAGE EVEN WHEN THE CAMERA OR INTENSIFIER POWER IS OFF. A CHIP OR INTENSIFIER DAMAGED BY LASER LIGHT IS NOT COVERED BY ITS WARRANTY.



Important instructions for safe camera handling:

- Fully read and understand the instruction manual of the specific type of camera.
- Put the protection cap on the camera lens whenever you do not take images, especially when the laser beam is adjusted. Switching off the camera / image intensifier does not protect the chip from damage by laser light.
- Use full resolution of the sensor and always read out the complete chip to have control of the intensity on all areas of the sensor.
- Make sure that no parts of the image are saturated, i.e. the intensity is below maximum gray level (< 4095 counts for a 12 bit camera, < 65535 counts for a 16 bit camera, ...).

- Start measurements with the lowest laser power and a small aperture of the camera lens.
- Increase laser power step by step and check the intensity on the corresponding image. Make sure that the sensor does not run into saturation.
- Bright parts in the experiment, like reflections on walls or big particles, will limit the maximum laser power. Modify the optical arrangement of your setup in order to remove bright reflections from the camera image.

2 Network Interface Card (NIC) Configuration

2.1 Interface Configuration

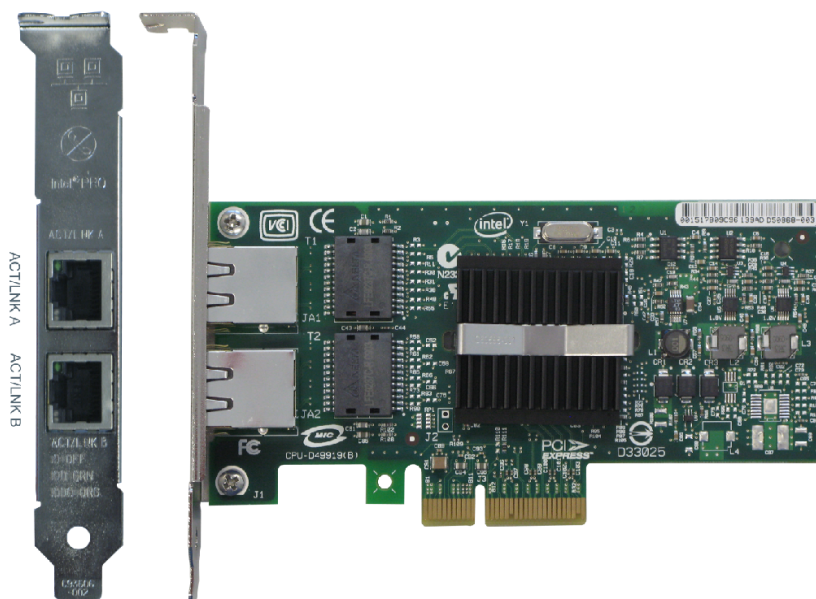

This paragraph describes how to connect the Phantom camera to a NIC like the (Intel Pro/1000 PT Dual Port, art. #1108215). This NIC is compatible to x4, x8, and x16 full-height and low-profile PCI-E slots. After the Network Card is installed physically into the computer Windows 7 will install the driver automatically. Connect the camera on one of the network ports of the Dual Port Card and proceed with the following steps.

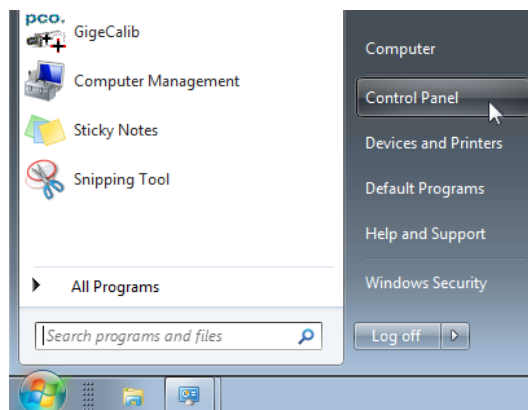

Open the taskbar and click on **Control Panel**

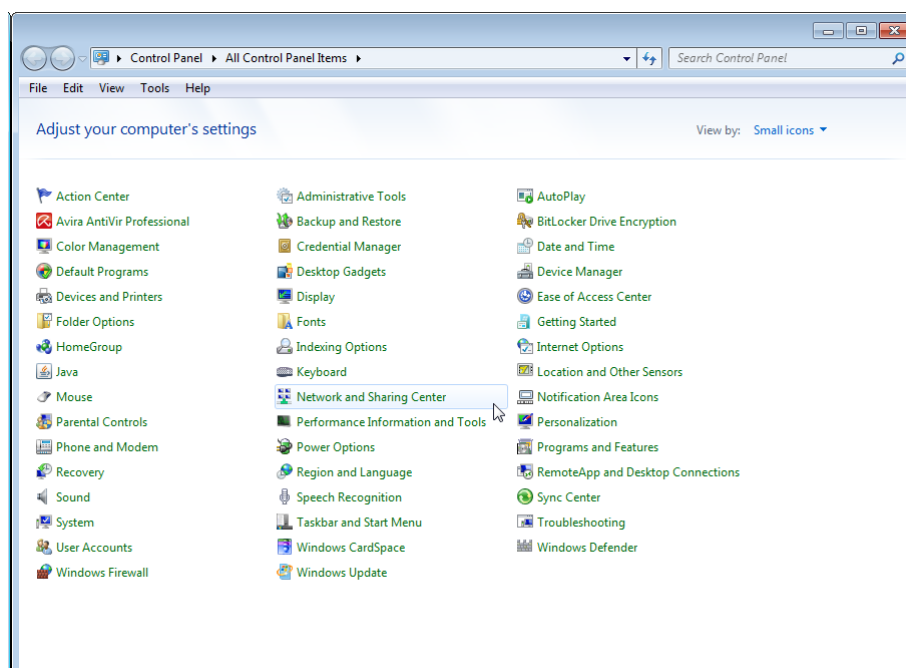

Click on **Network and Sharing Center**

2.1 Interface Configuration

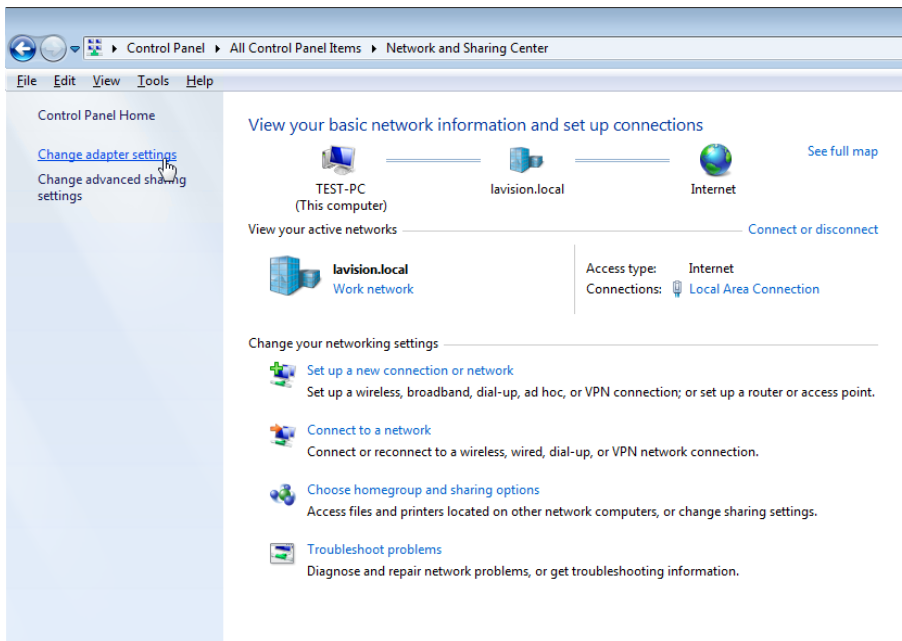

On the left side click on **Change Adapter Settings**

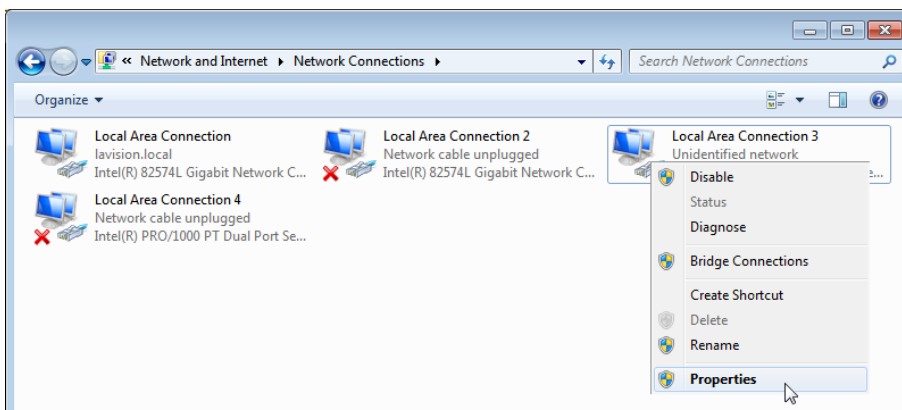

There are 2 connections for the dual port card, the one on which the camera is connected is signed as **Unidentified Network**. If the camera is not switched on yet, turn it on and the port on which the card is plugged in will try to identify the camera. Use a right click on the network port to which the camera is connected and click on properties

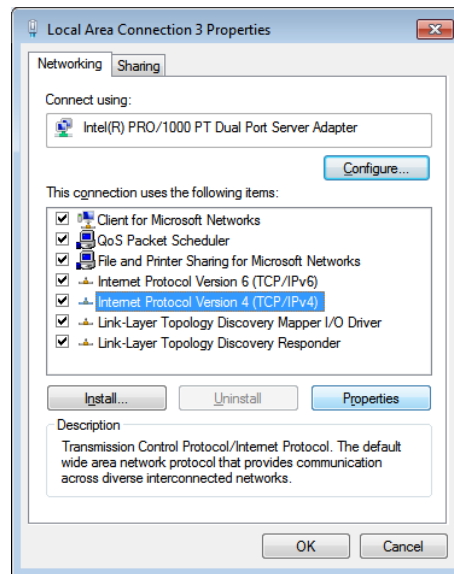

Select **Internet Protocol (TCP/IP)** and click the **Properties** button

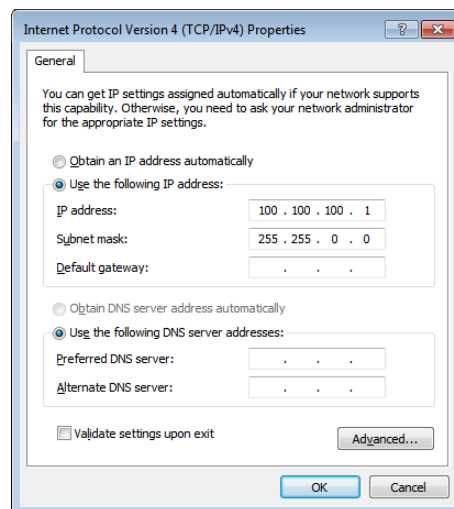

Check: **Use the following IP address:** and enter:

IP address : 100.100.100.1

Subnet mask : 255.255.0.0

Leave the **DNS** field empty. Click **OK** to close the window and restart the PC.



The firewall has to be disabled or DaVis has to be added as an exception. Otherwise the camera can not be initialized by DaVis.

Further cameras can be installed by using an GigE Network Switch like in the picture below.

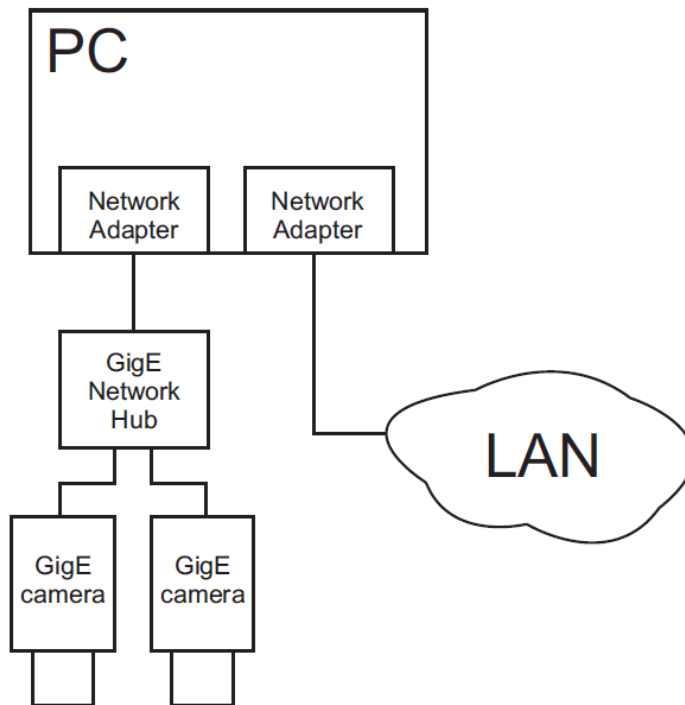

3 Phantom Miro M-series

3.1 Important Safety Instructions

All Phantom cameras and peripherals have been designed and produced according to the relevant safety standards. Although the mechanical design is extremely rugged and stable, the content, high-tech micro electronics deserves a careful handling.

3.2 General

Do not open the product; there are no user serviceable parts inside. All maintenance and service work should be performed by qualified service personnel. The cameras are intended to be used in restricted access areas.

3.3 Installation

- Do not expose your cameras and peripherals to excessive heat, moist and dirt. They are intended to be used in a controlled environment, unless precautions have been taken for outdoor use.
- The cameras and peripherals should only be powered from an appropriate DC power supply that fulfills the local safety and EMC demands or the appended AC adapter.
- Do not install the camera in an excessively humid environment or near water.
- Avoid liquids or any foreign object to get into the product.
- The unit must be placed in a sufficiently ventilated area; the ambient temperature should not exceed the specified temperature range.
- It is important that ventilation air can move freely around the unit.

3.4 Temperature

The Phantom Miro M-series cameras are designed to operate satisfactorily in an environment where the ambient temperature is between 0°C and 40°C (32°F and 104°F). The maximum humidity is 80%, non-condensing, at 5°C.

Applicable Conditions: Since the maximum allowable case temperature is 40°C (104°F) under free access conditions and 50°C (122°F) under restricted access conditions, it is recommended to use the record mode only shortly and keep the camera in pretrigger mode in order to avoid over temperature.

3.5 Storage

Store the camera in a dry location, storage temperature must be within -25 +85°C (-13°F and 185°F).

3.6 Shipping

When shipping the Phantom cameras and accessories, use the case in which the unit was originally delivered.

3.7 Precautions



A laser beam focused on the sensor of a Phantom camera, either directly or by reflection, can cause permanent damage to the sensor. Any laser powerful enough to produce localized heating at the surface of the sensor will cause damage, even if the camera power is off. A sensor damaged by laser light is NOT covered by warranty.

3.8 FCC Declaration Not Obligatory for CE

This equipment has been tested and found to comply with the limits for a Class B digital device, pursuant to Part 15 of the FCC Rules. These limits are designed to provide reasonable protection against harmful interference in a residential installation. This equipment generates, uses and can radiate radio frequency energy and, if not installed and used in accordance with the instructions, may cause harmful interference to radio communications.

However, there is not guarantee that interference will not occur in a particular installation. If this equipment does cause harmful interference to radio or television reception, which can be determined by turning the equipment off and on, the user is encouraged to try to correct the interference by one or more of the following measures:

- Reorient or relocate the receiving antenna.
- Increase the separation between the equipment and receiver.
- Connect the equipment into an outlet on a circuit different from that to which the receiver is connected.
- Consult the dealer or an experienced radio/TV technician for help.

3.9 Phantom Miro M-series Specifications

Model	M 110	M 310	M 120	M 320S	M 140	M 340
Resolution	1280 x 800	1280 x 800	1920 x 1200	1920 x 1200	2560 x 1600	2560 x 1600
Rate / Hz	1630	3260	730	1380	410	800
Rate @512x512 / Hz	5790	11500	5580	9200	5530	9290
Sensor format / mm	25.6 x 16	25.6 x 16	19.2 x 12	19.2 x 12	25.6 x 16	25.6 x 16
Min. interframe time/ μ s ¹	0.5	0.5	1.4	1.4	1.4	1.4
Pixel size / μ m	20	20	10	10	10	10
Dynamic Range A/D / bit	12	12	12	12	12	12
Memory / GB	3, 6, 12	3, 6, 12	3, 6, 12	3, 6, 12	3, 6, 12	3, 6, 12
Interface	GigE	GigE	GigE	GigE	GigE	GigE
Dimensions / cm ³	19 x 9 x 10	19 x 9 x 10	19 x 9 x 10	19 x 9 x 10	19 x 9 x 10	19 x 9 x 10
Weight / kg	1.4	1.4	1.4	1.4	1.4	1.4
Operating temperature / C°	0-40	0-40	0-40	0-40	0-40	0-40
Power requirements / VAC	100-240	100-240	100- 240	100-240	100-240	100- 240
Lens mount	F-mount	F-mount	F-mount	F-mount	F-mount	F-mount

[1] Shutter off mode, The min. interframe times without shutter off mode are longer. Typical values are 2 to 4 μ sec. The exact value depends on the camera model and firmware version.

3.10 Spectral Response Curves

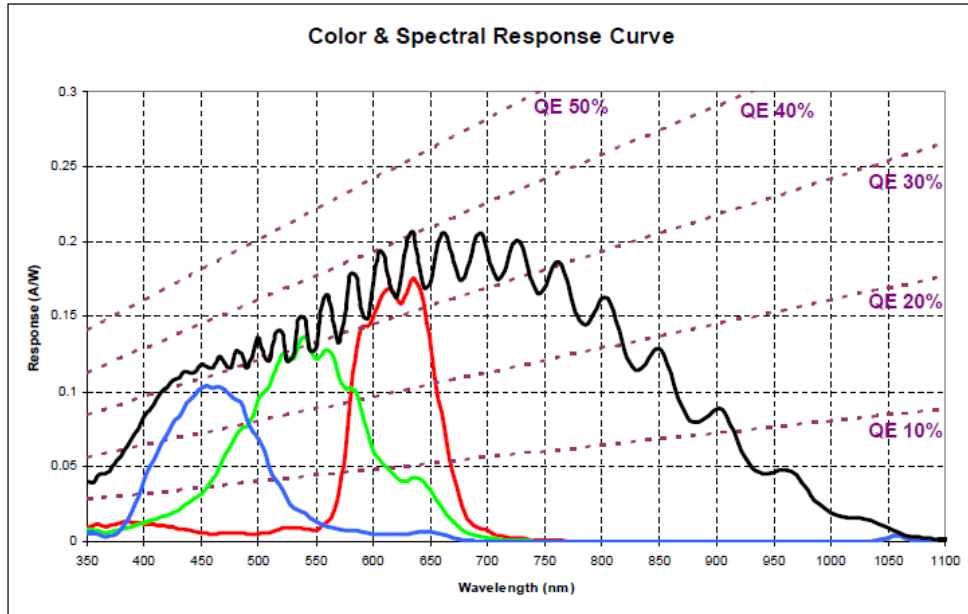

Figure 3.1: Spectral response curve for Miro Mx10.

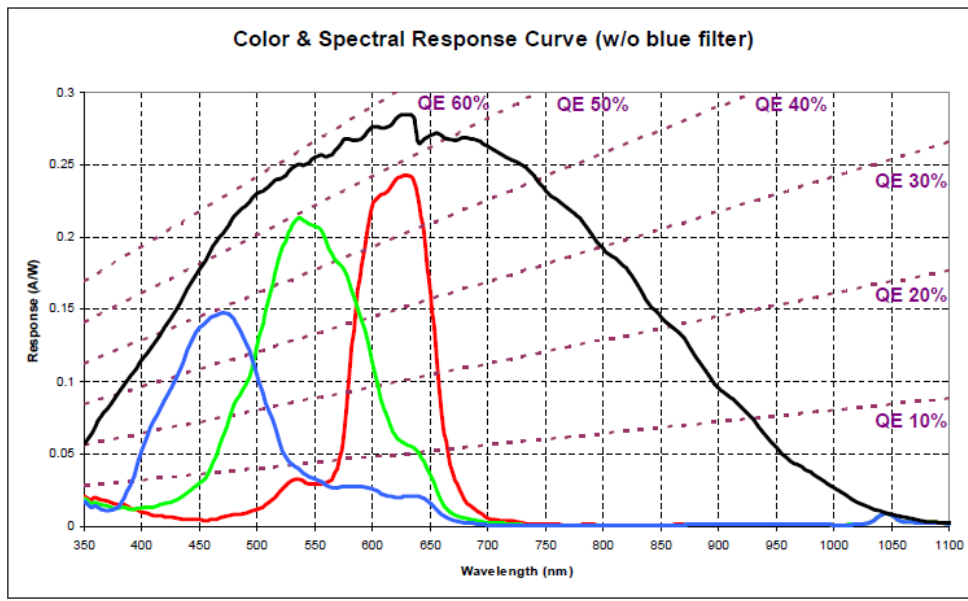

Figure 3.2: Spectral response curve for Miro Mx20.

3.11 Camera Connectors and Indicators



Figure 3.3: Phantom Miro M110.



Figure 3.4: Phantom Miro M310.



Figure 3.5: Phantom Miro M120.

3.12 Camera Connector

PIN	NOMENCLATURE	FUNCTIONAL DESCRIPTION
A	Event In	Event is an active-low isolated input whose state is recorded at the end of each exposure. The signal must be active when the strobe goes high, and be at least $30\mu s$ long to guarantee it is properly recorded.
B	Trigger In	<p>Isolated input. Active low. It can be activated by a switch to ground. On early cameras the trigger was level-sensitive, and was accepted if asserted (low) at the end of an exposure. As such, the trigger signal should have lasted at least as much as the reciprocal of the frame rate to guarantee it was recognized.</p> <p>Now the trigger is edge-sensitive, and the exact time of the trigger edge is recorded. The trigger pulse needs to be at least $3\mu s$ long.</p>
C	Strobe Out	Isolated open collector output, with 1k pull-up. When asserted (low) Strobe indicates that the camera integrates (the shutter is open). Strobe is low for the duration of the exposure.
D	IRIG- In (Unmodulated)	Phantom v710, v640, v310, v210, and v12.1 Cameras provide unmodulated IRIG B time code inputs and outputs. The input withstands signals of up to $\pm 15v$. The input threshold is 1.5V, so the input is also compatible with TTL levels. The output swings to RS-232 levels of $\pm 9V$.
E	IRIG Ground	
F	Video Out (Composite)	The video output of the Phantom cameras is a standard level, 75-ohm output. It is not isolated. The video output should only drive a properly terminated (75-ohm) input. Also, for anything but the shortest cable runs, quality 75-ohm coax (e.g. RG59/U) must be used.

3.12 Camera Connector



PIN	NOMENCLATURE	FUNCTIONAL DESCRIPTION
G	Video Ground (Composite)	Ground/Shield (For Video Out Signals)
H	Serial (RS-232) Ground	All the serial ports are not isolated (referred to system ground). As such, they should only be connected to properly earthed equipment.
J	Chassis Ground	
K	Transmit Data (RS-232)	Phantom v710, v640, v310, v210, and v12.1 cameras use true RS232 levels.
L	+24VDC	<p>Phantom cameras use DC (Direct Current) power. The nominal power supply voltage is 24VDC. The acceptable power supply range is 20-36VDC. Power supply inputs are protected against polarity reversal (with a series-pass diode). The cameras are also protected to under voltage and will shut down when the DC input is below circa 17VDC.'</p> <p>The power supply input terminals are isolated from the case and system ground. This is usually achieved by using a properly isolated power supply.</p> <p>NOTE</p> <p>Connecting the Phantom cameras to anything but a SELV (Safe Extra-Low Voltage) circuit will create an electrical shock hazard.</p> <p>The power supply Power (Watt) Rating should be rated 50% higher than ratings specified (for all camera models).</p>
M	Power Ground	The power input and the acquisition control signals are isolated from the camera system ground. This isolation is designed to avoid system ground loops only, and should not be subject to high voltages.
N	Aux	Presently unused
P	ISO Ground	Ground/Shield(For signals:A, B, C, R, and V)

PIN	NOMENCLATURE	FUNCTIONAL DESCRIPTION
R	Pre-Trigger In/ MemGate In	<p>Pre-Trigger</p> <p>This function allows the user to place the camera into the Ready State or Capture Mode when the falling edge of a 5V TTL pulse is detected.</p> <p>Memory Gate</p> <p>Active-low isolated input. When asserted, the current frame is discarded instead of being written into the memory. The decision is taken at the end of the exposure (after STROBE goes high). MemGate needs to be low the moment STROBE goes high and stays low for at least 15s to disable recording of the current frame.</p>
S	IRIG Out (Unmodulated)	Phantom v710, v640, v310, v210, and v12.1 cameras provide unmodulated IRIG B time code inputs and outputs. The input withstands signals of up to ± 15 V. The input threshold is 1.5V, so the input is also compatible with TTL levels. The output swings to RS-232 levels of ± 9 V.
T	GenLock	Used to lock the frequency of the frames to an external device.
U	Receive Data (RS-232)	Phantom v710, v640, v310, v210, and v12.1 Cameras use true RS232 levels.
V	Ready	Isolated open collector output, with 1k pullup. When high, indicates that the camera is in capture mode. In a multiple camera system, the READY outputs of up to 4 cameras can be connected together; the resulting signal will be high when all the cameras in the system are in capture mode.

3.13 Status LEDs

The LED indicators below provide you with a visual representation of the camera's operational state, and communication status.

3.13.1 Power Indicator

The Power LED provides a visual indication of camera power status and firmware integrity. If power is being supplied to the camera, and this LED is not lit, it indicates an error has occurred in the camera firmware. If this happens it is best to reboot the camera to correct the error.

3.13.2 Capture Indicator

The Capture LED provides a visual indication of the camera's operational states. By factory default, the camera is placed into the Preview - Waiting for Pre-trigger mode when the camera is powered on, unless it has otherwise been user-configured to start in the Recording waiting for trigger (capture) mode. Once in the Capture mode the camera starts recording images into the camera's circular memory buffer (DRAM). Upon detection of a trigger signal, the camera is instructed to stop writing to the camera's internal memory buffer, once the number of specified Post Trigger frames has been reached, and the camera will be placed into the Preview mode. If the camera has been configured to automatically save the images to Flash the camera will, at this point write the images stored in the camera's DRAM to the Flash module.

User intervention is required to either save the cine to an external drive, or to put the camera back into the capture mode from the Setup and Recording screen.

The following will indicate the camera's operational state described above:

- Off Preview or Preview - Waiting for Trigger
- On Recording waiting for trigger (capture)

3.13.3 Communication Indicator

When active the LED indicates data is being transferred between the camera and the Phantom Control Unit computer.

3.13.4 Ethernet Activity Indicator

When active the LED indicates data is being transferred between the camera and the Phantom Control Unit computer.

3.13.5 Ethernet Link Indicator

When active the LED indicates that the camera is detected and is connected to an Ethernet network.

3.14 Dimensions

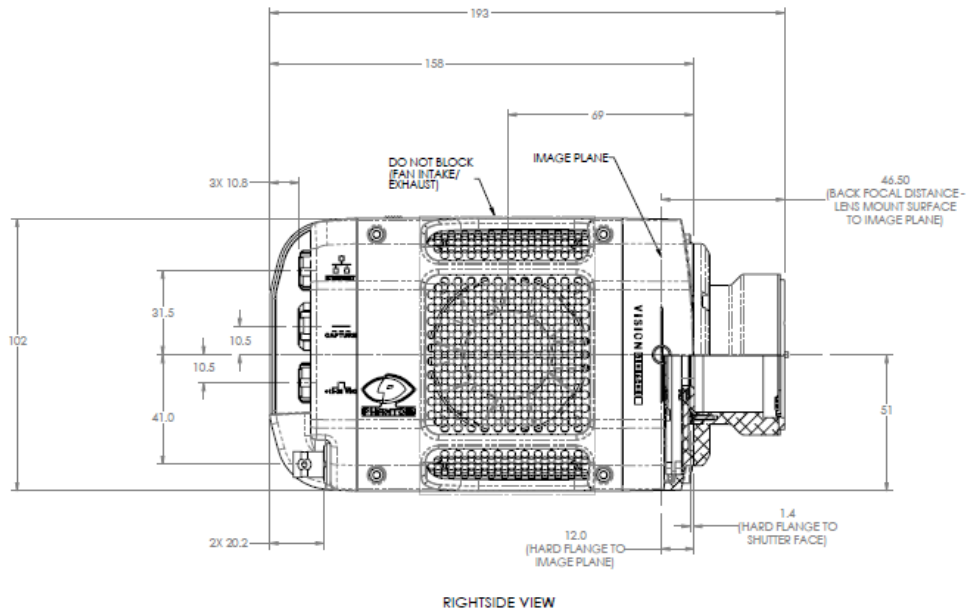

Figure 3.6: Right Side View

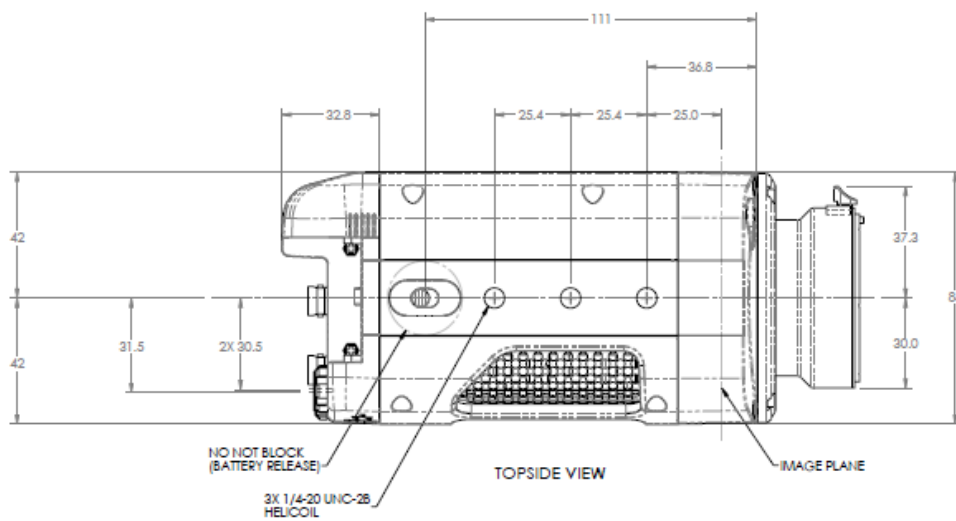

Figure 3.7: Topside View

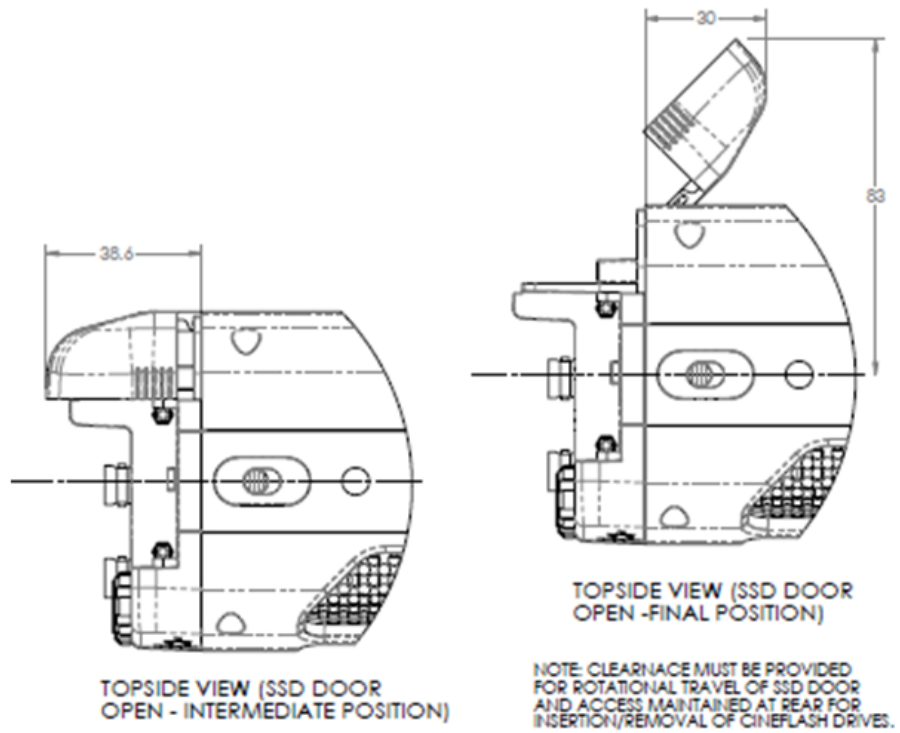

Figure 3.8: Topside View with possible SSD door positions

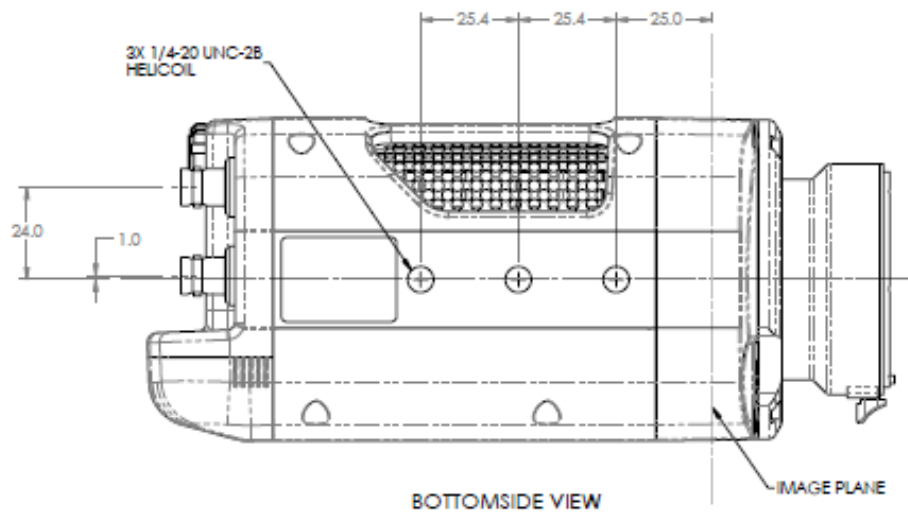

Figure 3.9: Bottomside View with possible SSD door positions

4 Phantom Wiring

4.1 Installing the Network Interface Board

Note: Normally you do not need to install any cards or boards in your delivered computer. The system is shipped with these components already installed. However during transportation these interface boards may become dislodged from their PC slots.

Caution: Before touching the PC-Interface-Boards make sure you have not accumulated static charges. A discharge may destroy the sensitive electronics and voids any guarantee.

Insert the network interface card in a free PCI-X slot of your computer and then secure with the screw to the PC housing. Make sure the board does not contact any electrical conducting parts (housing, other boards, wires or chillers).

4.2 Cabling and Connections

4.2.1 Wiring with one Phantom camera

You have to connect following cables to get the system ready to work:

- Plug in the Image camera connector 1007820 to the **Camera** terminal on the HSC rear panel.
- Connect the **Image Clock 1** line of the camera connector 1007820 to the F-Sync input on the back panel of the camera.
- Connect the **Trigger 1** line of the Camera connector 1007820 to the Trigger input on the back panel of the camera.

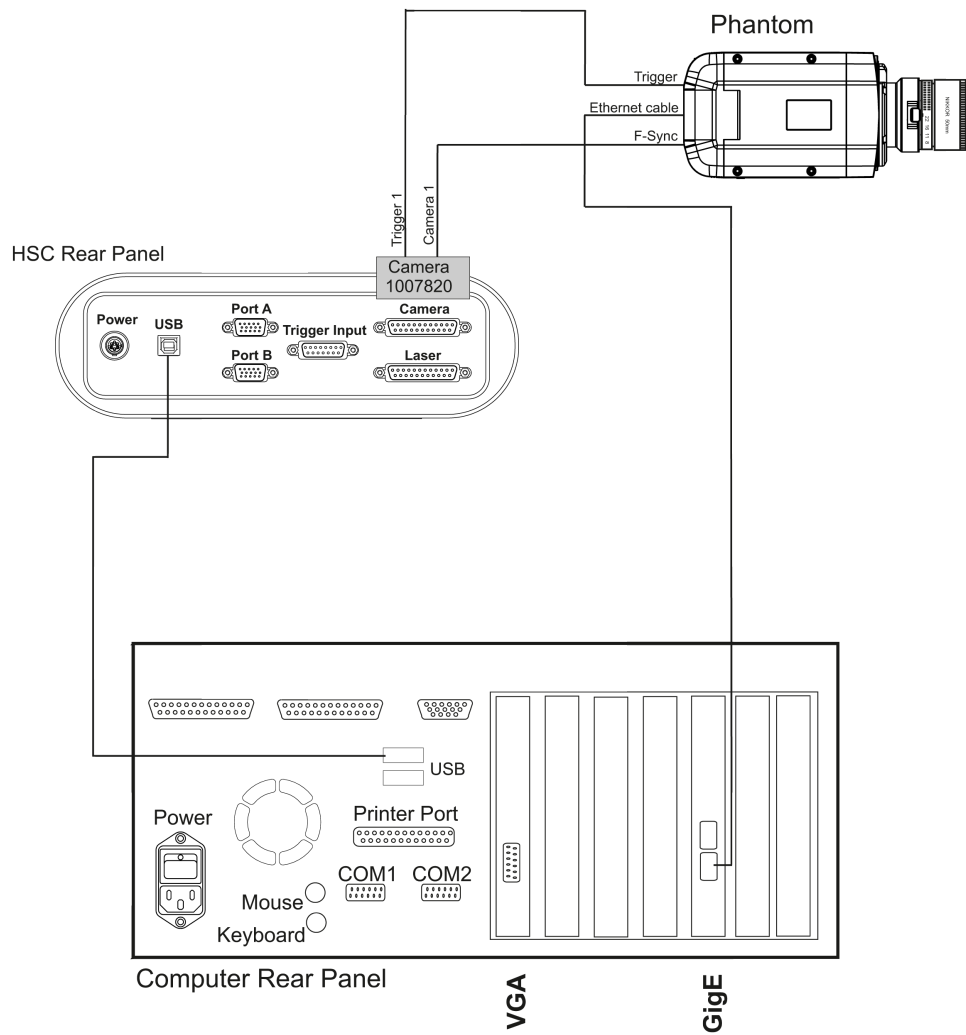

Figure 4.1: Wiring of a Phantom Miro camera system.



Note:

The two BNC connectors on the back of the Miro M320S are FSYNC (input) and HDSDI (output). The trigger line of the HSC has to be connected to the TRIGGER input of the cameras multi I/O connector.

- Connect the Dongle (software license) to a USB port.
- Plug in the power supplies.
- Switch on all devices. First camera, wait 30 seconds before switching on the computer!

4.2.2 Wiring with two Phantom cameras

You have to connect following cables to get the system ready to work:

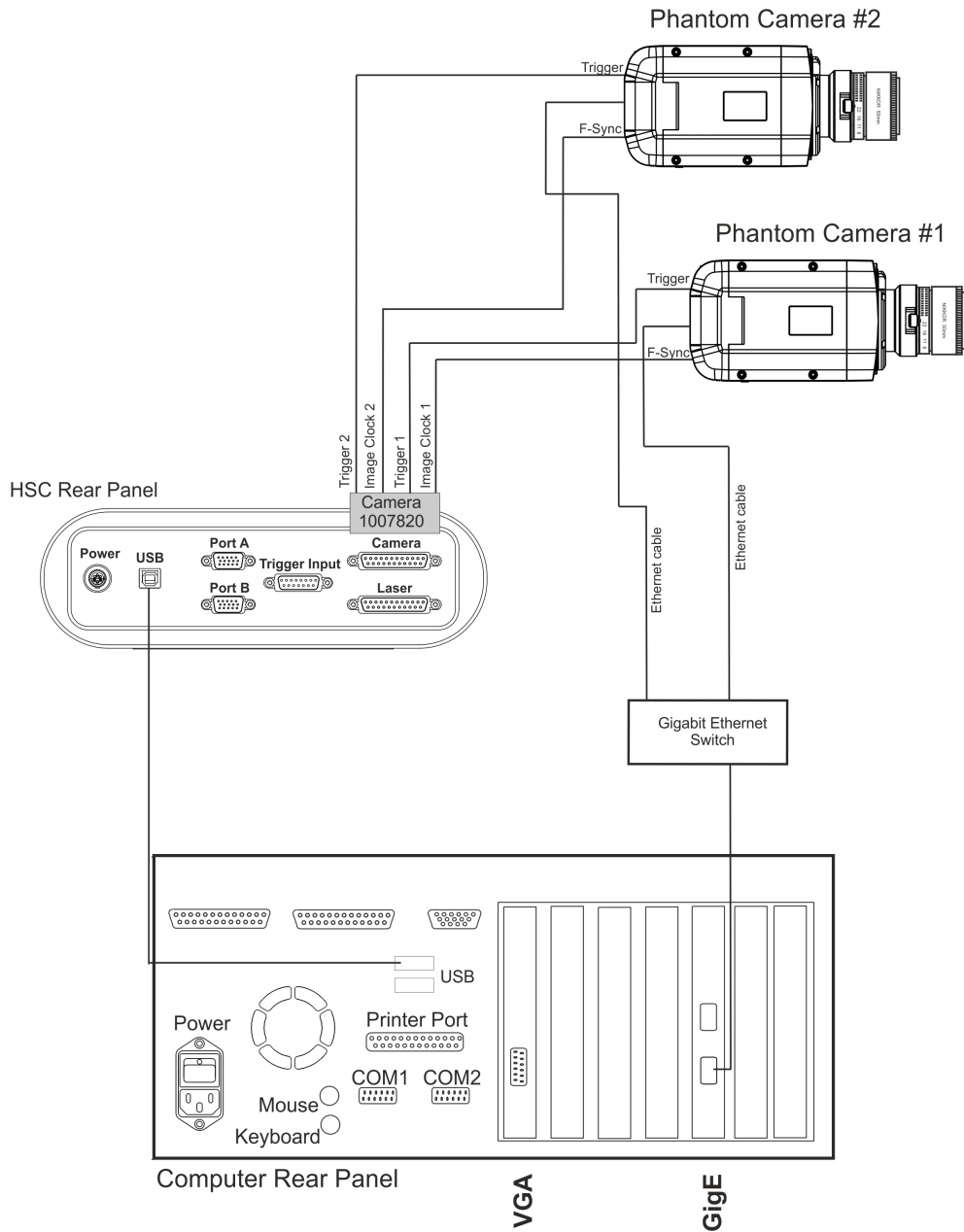

Figure 4.2: Wiring of a Phantom Miro camera system with two cameras.

- Plug in the camera connector 1007820 to the **Camera** terminal on the HSC rear panel.
- Connect the **Image Clock 1** line of the camera connector 1007820 to the F-Sync input input on the back panel of camera. 1.

- Connect the **Image Clock 2** line of the camera connector 1007820 to the F-Sync input on the back panel of camera 2.
- Connect the **Trigger 1** line of the Camera connector 1007820 to the Trigger input on the back panel of camera 1.
- Connect **Trigger 2** line of the camera connector 1007820 to the trigger input on the back panel of camera 2.



Note:

The two BNC connectors on the back of the Miro M320S are FSYNC (input) and HDSDI (output). The trigger line of the HSC has to be connected to the TRIGGER input of the cameras multi I/O connector.

- Connect the Dongle (software license) to a USB port.
- Plug in the power supplies.
- Switch on all devices. First camera, wait 30 seconds before switching on the computer!

5 Hardware Setup

The camera is initialized in the **Hardware Setup**. This dialog can be reached by clicking the **Settings** button in the **DaVis** toolbar. This button is only available if no Project is open. The camera is usually initialized as a sub-device of the HighSpeed Controller (HSC).

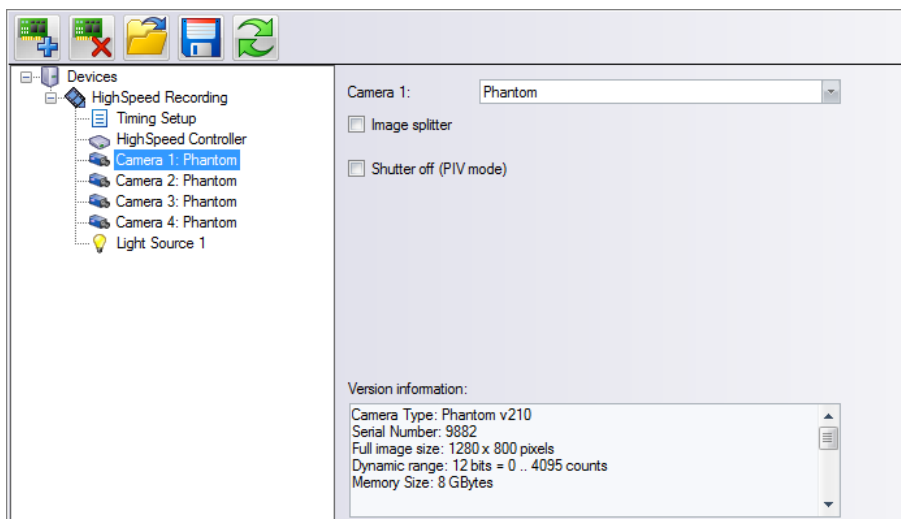

The camera setup dialog for this camera type will appear. After initialization of the camera you will get the version information displayed in the dialog.

After the camera installation has been completed the camera is registered within your program environment.

Note:

If more than one camera is installed the camera with the lowest serial number is selected as camera 1. The other cameras are initialized in the order of the serial numbers.

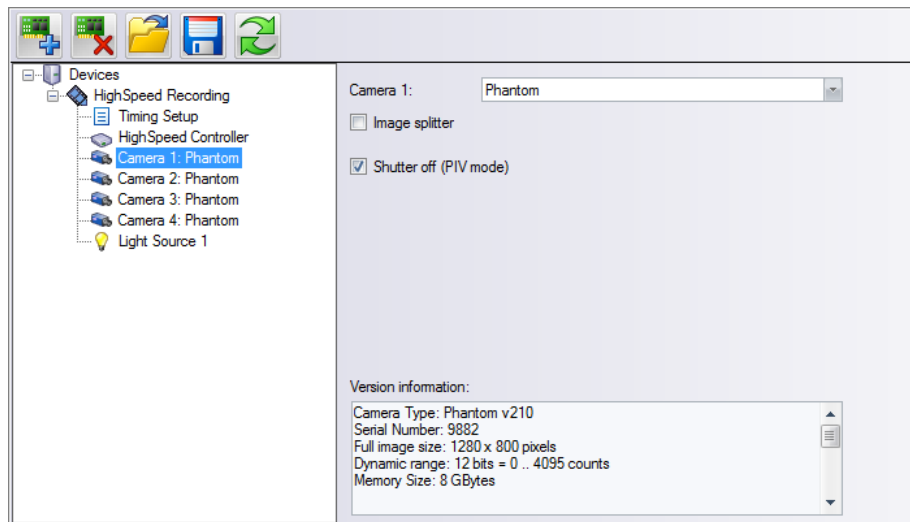

If Shutter off (PIV mode) is activated the electronic shutter (exposure control) is switched off. In single frame recording the exposure time is automatically set to the maximum value ($1 / \text{rate}$) and cannot be changed. In double frame recording the shutter off mode enables the shortest possible PIV dts. Please check the table of specifications (section 3.9) for the values for the cameras.

6 Device Settings

The **Devices** card can be opened using the **Setup** button, e.g. in the **Recording**, **Interactive correlation** or **Calibration** dialog.



6.1 Camera: Phantom

On this card you can select the resolution of the camera in pixel and the dynamic range in bits. The selected resolution determines the maximum image rate. The number of images that can be recorded into the cameras RAM depends on the selected resolution and the selected dynamic range. These figures are displayed in the dialog.

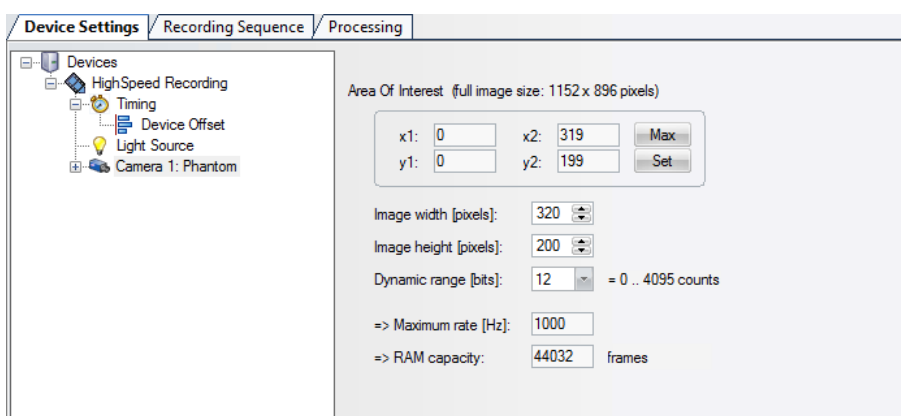

The resolution can either be selected with the mouse (button **Set**) or directly be entered in the dialog (image width and height).

Please note the resolution can only be changed in the steps that the camera supports (128×8 pixels). **DaVis** automatically selects the best possible for the selected value.

6.1.1 Scales and Overlays

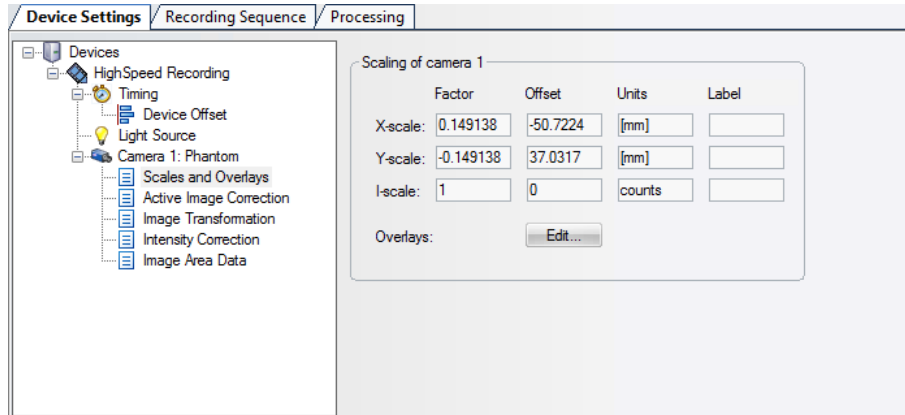

On this card the horizontal X-scale, vertical Y-Scale and intensity I-scale are defined for a camera. Each camera possesses its own scales. All scales map X/Y/I are using the equation $x' = ax + b$, where x is the original position (or intensity) in units of pixels (or counts) and x' is the new scale value, a is the factor and b is the offset. The default setting are $a = 1$ for the factor and $b = 0$ for the offset.

The camera overlay include drawing information, e.g. marked areas or additional texts, which are painted above the image. This overlays are copied into the destination buffer during image acquisition. Press button **Edit** to open the **Overlay Editor**.

6.1.2 Active Image Correction

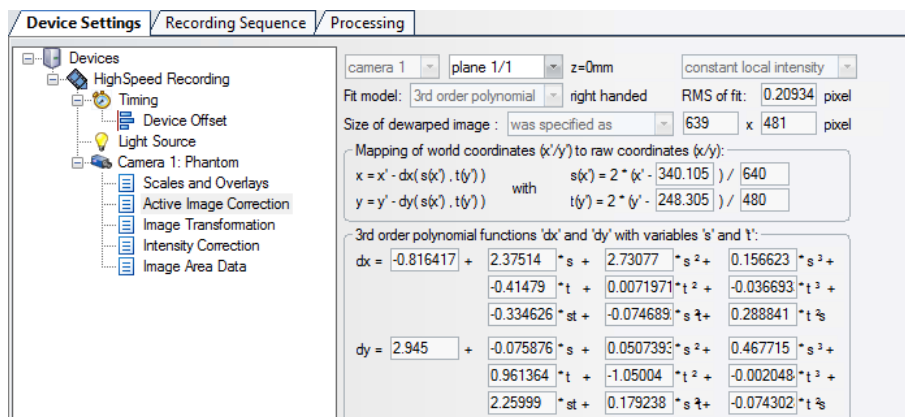

Optional the camera raw images may be corrected by the active image correction function. On the **Active Image Correction** card the active fitting function is displayed.

6.1.3 Image Transformation

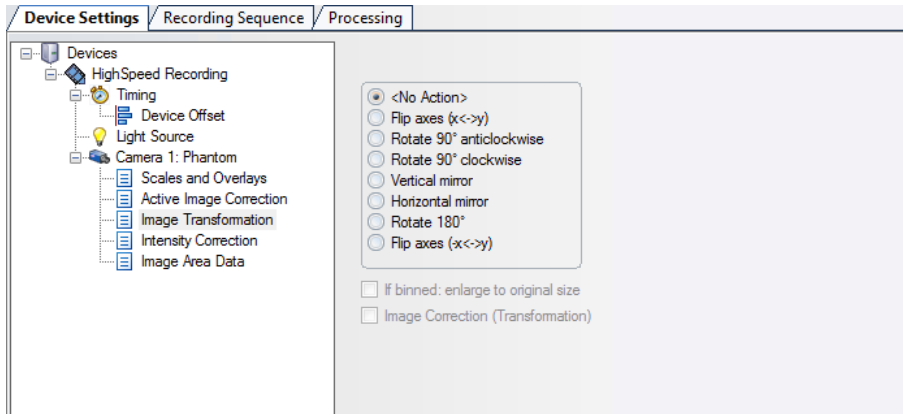

The way in which the CMOS image is transferred to the image buffer can be set in different modes. It concerns only the way of image storage and not the reading procedure.

Example: For a given experimental setup, all acquired images appear upside down. If **vertical mirror** is chosen, they appear in the 'correct' way. These actions need quite a while, we advise to use these functions only via the batch processing after the image acquisition is completed.

Following image transformation options are available:

- **No Action:** The image is not changed (default).
- **Flip axes ($x \leftrightarrow y$):** The image is mirrored on the first diagonal. The result is an image with exchanged x and y axis.
- **Rotate 90° anticlockwise:** The image is rotated to the left by 90° (useful if camera is mounted rotated).
- **Rotate 90° clockwise:** The image is rotated to the right by 90° (useful if camera is mounted rotated).
- **Vertical mirror:** Applies a vertical mirror.
- **Horizontal mirror:** Applies a horizontal mirror.
- **Rotate 180°:** Rotates the image by 180°.
- **If binned: enlarge to original size:** When binning is used during image acquisition the acquired image is enlarged to the maximum chip size.
- **Image correction:** Image correction is applied to all images during acquisition. The corresponding mapping function can be loaded using the **Calibration** dialog (see **Calibration** chapter).

6.1.4 Intensity correction

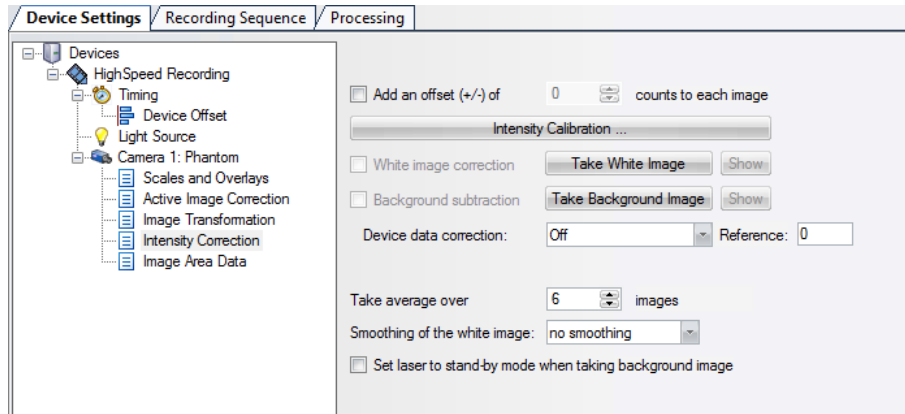

The **Intensity Correction** card can be used for a correction of the fix pattern noise of a CMOS camera. Additionally you can activate a subtraction of an offset, white image or a background.

- **Add an offset (+/-) of N counts to each image:** Using this option you can add or subtract a constant offset from the image intensity.
- **Intensity calibration:** The Phantom camera has a calibration function (current session reference) that corrects the non-uniformity in output of each pixel based on black level. For the best result of recording it is strongly recommended that whenever you change framing parameters such as frame rate, exposure time, etc., you carry out the calibration of the camera before starting a recording.



The **Intensity calibration** button opens another dialog where you have to confirm to do a new intensity calibration. For the intensity calibration the camera lens must be closed. If your camera has an internal mechanical shutter this will close automatically during intensity calibration. You do not have to put a cap on the lens.

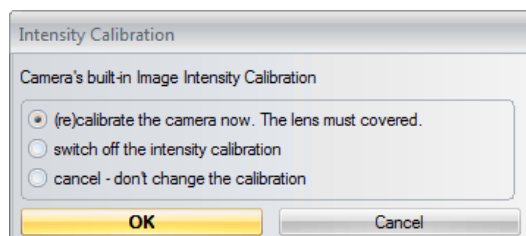

- **White Image Subtraction:** In case the 2D intensity distribution of a homogeneously light emitting object is not flat the 2D detection efficiency can be corrected by acquiring an image of a homogeneously illuminated object (e.g. white paper or milky glass table). The white

6.1 Camera: Phantom

image subtraction can only be done when dark image subtraction is activated. It is performed via division of each acquired image with the normalized correction image.

- **Background Subtraction:** Let us assume, e.g. a Laser Induced Fluorescence (LIF) experiment. Apart from the desired fluorescence signal, a Rayleigh-signal might be present (depending on the used filter). But as you want to detect a fluorescence image, we can consider the dark current and Rayleigh signal as undesired background. In this case acquire a Rayleigh image (LIF-experiment conditions without fluorescence molecules) as background. Now the dark current and the Rayleigh-signal are automatically subtracted from each acquired image.
- **Correction on device data value:** Each camera intensity can be **corrected on a device data value**, read from a device data source. All available sources are selectable in the list, or the correction can be switched **off**. When using this intensity correction, a reference value must be defined to execute the following function on the camera image:

$$I_1(x,y) = I(x,y) / I(\text{Value}) * I(\text{Reference})$$

Using the corresponding **Take** button you may **Take an average over N images**. Additionally you may **Subtract an offset of N counts for dark and background images**.

6.1.5 Image Area Data

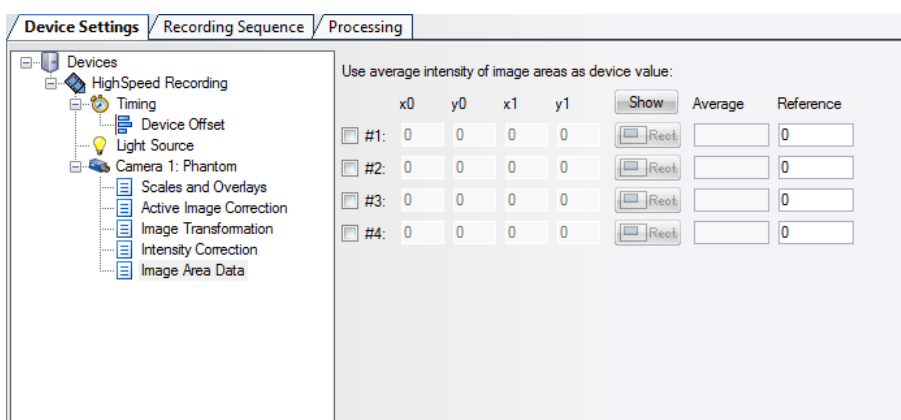

On this card you may define up to four rectangles in the camera image. On these rectangles the average intensities is calculated and stored as device data. This allows to display these intensity values during image acquisition

what can be useful e.g. to adjust the gain of an optional image intensifier in a low light application in order to get a suitable signal intensity.

7 Troubleshooting

7.1 Camera Serial Number not registered

The support of the Phantom camera is protected by its serial number. If the serial number is not registered at **LaVision** the camera will not be initialized and supported in **DaVis**. In this case you will obtain a corresponding error message at the startup of **DaVis** or after first access to this camera.

If you need to operate a non-registered Phantom camera please contact your local representative or **LaVision** service directly.

7.2 Camera cannot be initialized by DaVis

- Camera cannot be detected by **DaVis**
 - Is the camera turned on and ready?
 - Is the IP address NIC set correctly (100.100.100.1)
 - Is the Windows Firewall disabled or **DaVis** added as an exception?



Note

After **DaVis** update the executable file of the new installation has to be added as exception.

7.3 The camera shows no live images on Take/Grab

- Check the wiring
 - Is the output Image Clock 1 (Image Clock 2 for camera 2...) connected to the F-sync input on the back panel of the camera 1?

7.4 Reset the camera to factory default

- Reset the camera to factory default. This can solve issues like:
 - Camera cannot be controlled from **DaVis**
 - Camera images show bad pixels
 - Memory of the camera is not correctly displayed in **DaVis**
- Procedure
 1. Connect the Phantom camera to the control PC via the ethernet connection
 2. Power on the camera and wait for the camera to completely boot.
 3. Power on the control PC and wait for Windows to completely boot.
 4. Left-click the Windows 'Start' button
 5. From the Windows Start Menu, select 'Run' (usually this located on the bottom right side)
 6. In the Run program locate the field labelled 'Open' and type: cmd
 7. Click the 'OK' button
 - At this point the Windows command line interface will open
 8. Open the Windows command prompt.
 - For Windows Vista and 7:
 - * From the Windows Start Menu, select Control Panel
 - * Select 'Programs and Features'
 - * Select 'Turn Windows features on or off'
 - * Check the 'Telnet Client' box
 - * Press 'OK' button
 - * From the Windows Start Menu, type "cmd" in the search bar
 - * Click the 'cmd.exe' link from the Programs list of the search results
 9. At this point the Windows command line interface will open
 10. In the Windows command line interface, type: telnet <Camera IP Address> 7115

7.4 Reset the camera to factory default

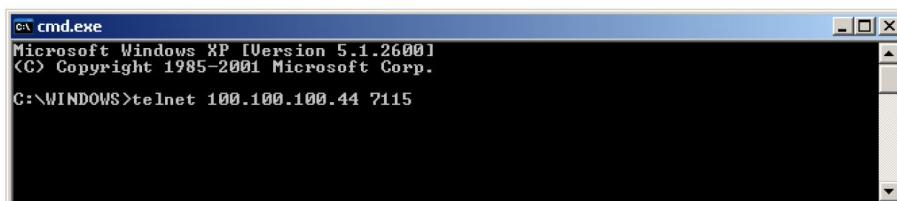

```

C:\WINDOWS>telnet 100.100.100.44 7115
  
```

Figure 7.1: Telnet command

- <Camera IP address> must be replaced with the camera's IP address. This information can be found on the IP decal on the bottom panel of the camera.
 - Example: if the camera's IP address is: 100.100.100.44, one would type: i. telnet 100.100.100.44 7115
11. Press the 'Enter' button
 12. Press the 'Enter' button again
 13. Type the following command: iload

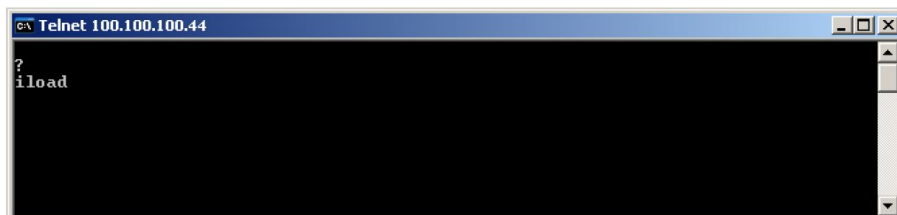

```

?
iload
  
```

Figure 7.2: iLoad command

14. Press the 'Enter' button
 - If the iload procedure is successful, the user will see the message "OK!"

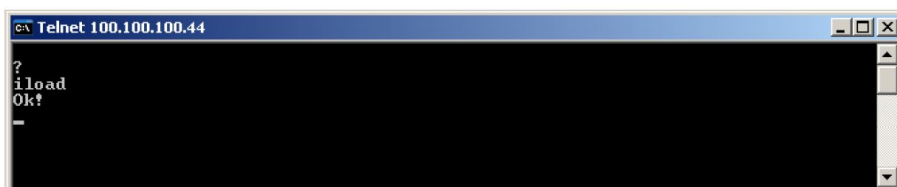

```

?
iload
Ok!
-
  
```

Figure 7.3: Successful iload message

- If the iload procedure is unsuccessful, the user will see the message: "ERR: factory defaults load failed"



Figure 7.4: Unsuccessful iload error message

15. If the iload is unsuccessful as described in Step 12.c, repeat Steps 11-12.
16. If the iload is successful, close the command line interface and reboot the camera.
 - The camera settings are now restored to the original factory defaults.

8 Customer Service

If you have a technical problem or questions regarding hardware or software which is not adequately addressed in the documentation please contact your local representative or **LaVision** service directly.

In order to speed up your request please include following information:

- The order number of your system (see section 8.1).
- The number of the used dongle (see section 8.1).
- A short description of the problem.
- Your customer settings file (see section 8.2).
- A log.txt if you have a reproducible software problem (see section 8.3).
- An information on the used operating system and service pack.

You can contact service at **LaVision** GmbH by:

email: service@lavisoin.de

phone +49 551 9004 229

Alternatively you may submit your problem using the service request interface on the **LaVision** homepage under the URL www.lavisoin.com.

8.1 Order and Dongle Number

To be able to find information on the delivered hardware components and customer details in the database your order number is required. This number can be found in the **DaVis/Help/About** menu or on the original **DaVis** installation CD (see Fig. 8.1).

In the **About DaVis** dialog you find the order number in the 3rd line. The five digits behind the leading X are the order number followed by the **DaVis** version and the release date.

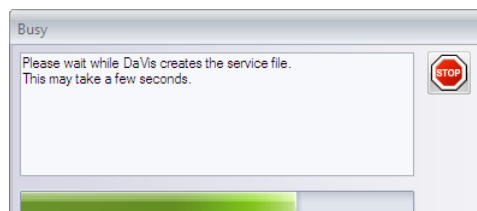

Figure 8.1: Order no. in **DaVis/Help** and on installation CD.

The dongle number is required to exclude license problems. This number is written on the hardware key. The number of the used dongle can also be found using the **DaVis/Help/About** menu and on the **DaVis** CD. Please include the order number and the dongle number in your service requests.

8.2 Customer Settings

To be able to reproduce your problem it could be essential to know the exact hardware setup and software parameter in **DaVis**. All currently used parameter can be extracted using the **DaVis/Help/Create service file for LaVision Support** menu.



After you have selected this the system will write back all values for the relevant variables to an Isf-file. This procedure will take a while indicated by a **Busy** dialog. The Isf-file will also contain the current settings of the hardware setup, acquisition setup and processing operation lists.

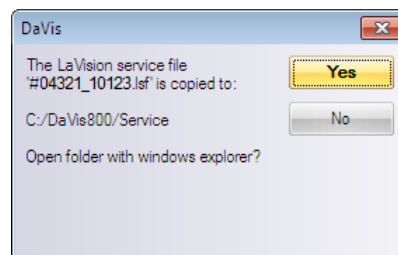

8.3 Log file

The Isf-file will be written automatically to a `~\davis\service` subdirectory. The name contains the order number and dongle number that is extracted from your software (`#ordernumber_donglenumber.lsf`). Send this Isf-file as attachment to the description of your problem by email to `service@lavidion.de`.

8.3 Log file

During startup of **DaVis** a log file named `LOG_<data>_<time>.txt` is generated in the **DaVis** main directory with date and time of the **DaVis** startup, e.g. `LOG_140804_150343.txt`. **DaVis** holds the last ten log files and removes older ones automatically.

If you have a reproducible software problem in **DaVis** please send the latest log file together with your email. This file contains all functions you have called and all error messages that have been displayed after you have activated the log. Please proceed as follows:

- Start **DaVis** and use the **Macro/Clear Log file** menu.
- Enable the **Log each CL function call (slow)** entry in the Macro menu. This feature is active if you see a flag left next to the entry. Every time you click on this entry its status is changed.

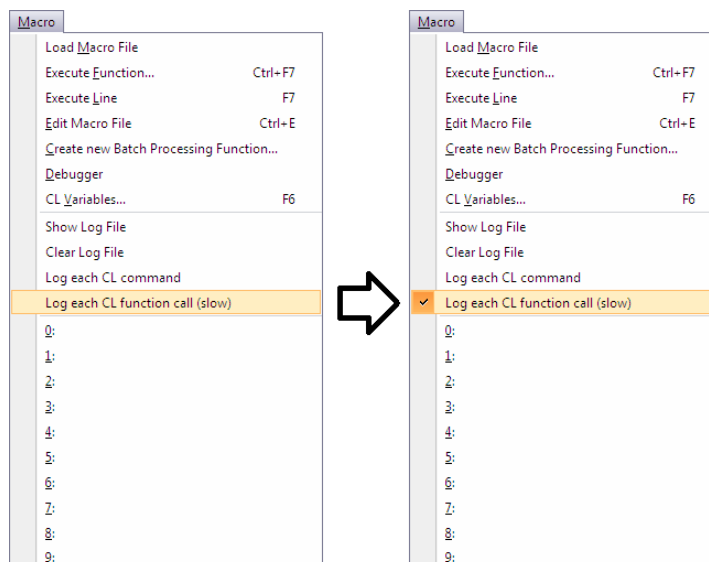

- Try to reproduce your problem, e.g. until an error message is displayed.

- A log file has been generated in the **DaVis** main directory. Send this text file attached to your email.
- Disable the **Macro/Log each CL function call (slow)**. This function is deactivated if you don't see a flag next to the entry.

8.4 Export data set for support

Some problems can only be reproduced on images that contain particular information or artifacts. For error analysis it can be necessary to provide exemplary data that needs to be extracted from the corresponding project. Depending on the project type, number of used cameras and error the corresponding calibration and derivative data can be required as well.

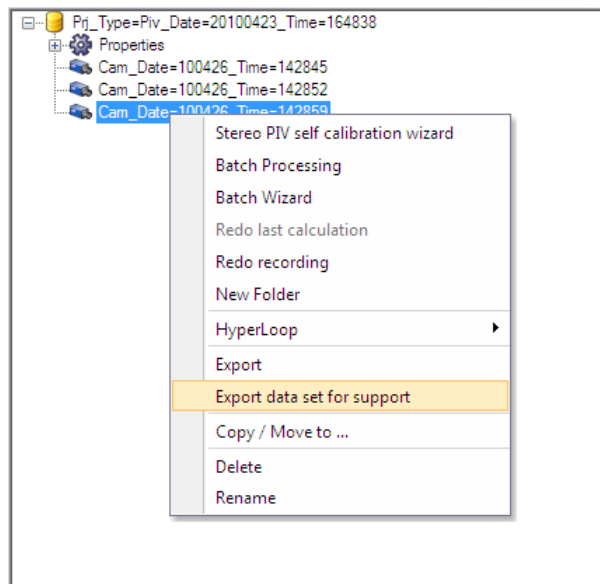

A convenient way to extract the data from the project is the **Extract data set for support** option that can be selected via right mouse click on the corresponding data set in the Project Manager.

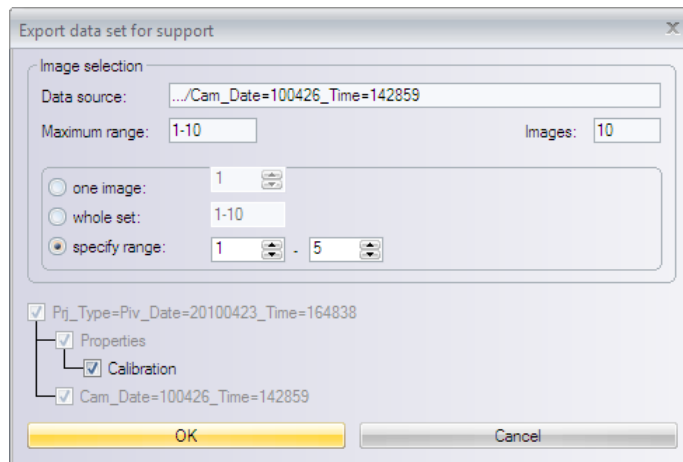

In the **Export data set for support** dialog the **Data source**, the **Maximum range** and the number of **Images** is specified. For the **Image selection** you need to select form following options:

one image: This will extract one image only. You need to select the number of the image.

whole set: This will extract the complete data set. Please note that depending on the number of images the resulting zip-file will be very large.

specify range: This will extract the specified range. You need to select minimum and maximum image number.

In addition you may activate the **Calibration** option and the corresponding cameras. This will make sure that the calibration for these cameras will be included.

Using the **OK** button you need to specify the location and file name for the zip-file that contains the selected data.

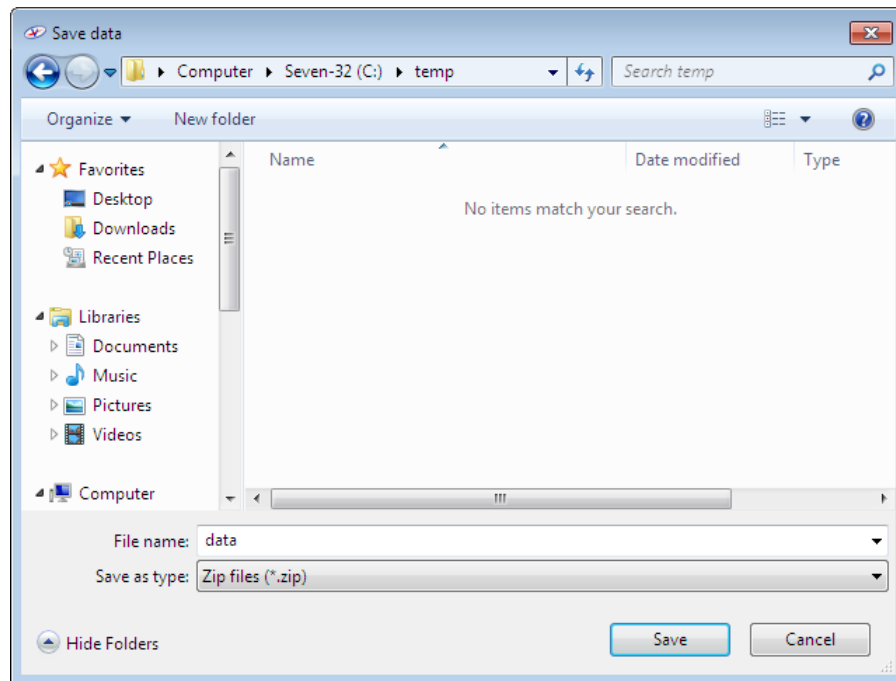

Note: Files with a size of more than 20 MB should not be send by email. **La-Vision** can provide a password protected location on a FTP server for data exchange with read and write access. Please contact service@lavision.de for details. For the upload your local user account needs to have enabled FTP functionality. Please check with your system administrator.

8.5 Camera Activity Logging

The camera support libraries (camera DLLs) used by **DaVis** have a built-in logging function which might be useful for camera activity monitoring and debugging. If you experience problems with camera behavior and contact **LaVision** support, you may be asked to generate a log file during camera operation and send it by email.

You can use the camera activity logging by choosing the appropriate item in the **DaVis Help** menus. Open the following modal dialog window which serves for starting and stopping the logging function, specifying logging options and viewing the resulting log output. If you create a `Isf-service` file after camera logging (see 8.2), the camera log data will be included.

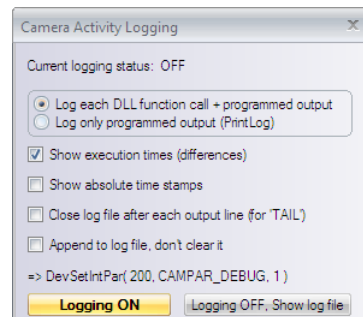

In the top line of the dialog the **Current logging status** is displayed. If this is not the 'OFF' status, a number is displayed. Using the following radio buttons you can choose if you want to **Log each CL function call + programmed output**, i.e. the complete communication between **DaVis** and the camera DLL, or to **Log only programmed output (PrintLog)**. Programmed output lines are the result of calls to the 'PrintLog' function inside the DLL or, from **DaVis**, results of a CL function call like `DevSetStrPar(DEV_CAMERA_1, CAMPAR_DEBUG, 'output string')`. If you choose **Log each DLL function call**, each `Get()` and `Set()` function call from **DaVis** to the DLL is logged together with the value of the parameter passed respectively the result returned by the DLL.

Using the four checkboxes you can specify the output format and writing mode:

Show execution times (differences): If this option is checked, each output line is preceded by the time passed since the preceding output line (microseconds).

Show absolute time stamps : If this option is checked, each output line is additionally preceded by an absolute time counter value (microseconds). This counter can be reset by calling the `TimerReset()` function inside the DLL

Close log file after each output line (for 'TAIL'): This options must be checked if a TAIL program is used for watching the log file, or if you expect a possible crash of **DaVis**.

Disadvantage: the logging is much slower (minimum time for an output line about 0.5 millisecond). If this option is unchecked, the log file remains open so you can view it only after switching the logging off.

Append to log file, don't clear it: If this option is unchecked, the output 'CameraLog.txt' is cleared (i.e. deleted) and a new logging is

started. If the option is checked, new logging output is appended to the existing file.

On the bottom of the dialog, the syntax of a CL function call is displayed which sets the logging (debugging) to the state displayed in the dialog window.

The **Logging On** button closes the dialog and activates the logging. After this, the activity of all cameras is logged in the 'CameraLog.txt' file. Unless you specify the 3rd option above, the file remains open for writing so you cannot view (read) it.

By clicking the **Logging OFF, Show log file** button you stop camera activity logging (if it was active). The resulting 'CameraLog.txt' file is closed and immediately displayed in a editor (default: ConText).

Logging is automatically activated when **DaVis** initializes the cameras during startup (or after clicking 'Initialize' in the Hardware Setup dialog). You can see initialization details, some camera properties or possibly error messages in the 'CameraLog.txt'.

8.6 Shipment of defective items

If some items need to be returned to **LaVision** GmbH for service or repair please contact the **LaVision** service to obtain a **RMA** (Return Material Authorization) number. Fill out the **Shipment Cover Letter** that is available in **DaVis/Help** directory, in the **Help** folder on the **DaVis** installation CD or at **LaVision** service. List all items with SN and a short description of the problem. Place the Shipment Cover Letter in the box with the item(s) being returned. Return the authorized item(s) per shipping instructions.

Shipping instructions:

- Be sure to obtain a RMA number.
- Include the Shipment Cover Letter.
- Ship only the items that are authorized.
- Use the original boxes to avoid damages during transportation.

- **Remove cooling water from the laser!**
- **Use antistatic bags for computer boards!**
- Ship returned items to:

LaVision GmbH
Anna-Vandenhoeck-Ring 19
D-37081 Goettingen
Germany

Note: Shipments received by **LaVision** without a RMA number may be refused.



LaVisionUK Ltd

Downsview House/ Grove Technology Park
Grove, Oxon, Ox 12 9FF/ UK
www.lavisionuk.com
Email: sales@lavision.com
Tel.: +44-(0)-870-997-6532
Fax: +44-(0)-870-762-6252

LaVision GmbH

Anna-Vandenhoeck-Ring 19
D-37081 Goettingen, Germany
www.lavision.com
Email: sales@lavision.com
Tel.: +49(0)551-9004-0
Fax: +49(0)551-9004-100

LaVision, Inc.

211 W. Michigan Ave., Suite 100
Ypsilanti, MI 48197, USA
www.lavisioninc.com
Email: sales@lavisioninc.com
Phone: +1(0)734-485-0913
Fax: +1(0)240-465-4306